



SAMSUNG TOOLING CATALOG

MD TOOLING, LLC
10139 BERGIN RD.
HOWELL, MI 48843
PHONE : 877-91-TOOLS (810-632-4446)
FAX: 877-92-TOOLS (810-632-4467)
EMAIL: info@mdtooling.com
WEBSITE: www.mdtooling.com

October, 2009

Live Tooling

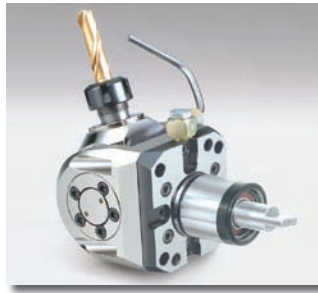

Live Tool Technology

M. T. Marchetti, a major live tool manufacture in northern Italy, is a leader in live tool technology. The formula is simple. Use only the best angular contact high-speed bearings available. Add to this exacting tolerances for all ground shafts, gears and bearing pocket features. Next, develop a sealed system that **will not** allow any contamination from chips or coolant.

Top this all off with a superior design and you end up with a live tool that is more rigid, faster and will last longer. **We back this up with a 2-Year factory warranty.**

Our Live Tool Warranty

Our tooling will give years of service in the most demanding applications. The superior design and rugged construction has proven this over the last 12 years. The reliability of our tools allows us to provide a 2-year factory warranty.

MD TOOLING will repair any defective tool holders for a period of 2 years from the date of purchase.

Product Range

We have the largest range of live tooling available for most major machine tool manufactures.

Our available products include an extensive line of standard live tooling as well as specialty toolholders such as 0-90 and 0-180 adjustable angle tool holders, gear hobbers, and even worm gear generators. Our product range includes geared up holders to 60,000 RPM and are engineered for 1,000 PSI coolant through.

We are an industry leader in providing complete tooling solutions with hundreds of static tool options as well.

Technical Support

Here at MD Tooling we have a full technical support department with over 25 years of CNC experience.

Our highly qualified staff can help with part processing, tooling up a job from a blue print and even assist with part programming. Applications Engineers are always available by phone to answer any questions you may have about our tooling or any other CNC related issue.

Stock and Replenishment

MD Tooling maintains an extensive inventory of tooling in our warehouse in Michigan. Our current "fill" rate on orders is 93% from our stock in Michigan for same day shipping.

Should you require a non-stock item, our manufacturer, M.T. Marchetti also maintains a large inventory in Italy. Tooling can be obtained in as little as 3-5 business days.

Shipping

MD Tooling realizes that when you need tooling, often you can't wait until the next day. We process orders and ship from available stock right up until 5PM EST to make certain we get your tooling solutions to you as quickly as possible.

We regularly ship throughout the day via DHL, UPS, FedEx or any other carrier that a customer requests.



10139 Bergin Road

Howell, MI 48843

Phone: 810 632-4446

Fax: 810 632-4467

Email: info@mdtooling.com

Web: www.mdtooling.com

- 2-Year Warranty on all live tools.
- Quality tooling at highly competitive pricing.
- Extensive inventory. We currently ship over 93% of all orders same day.
- Fast, Friendly, Reliable Service!
- More specialty tool holders than any other manufacturer.
- Custom tool holders available.
- All available tooling may not be shown in this catalog. If you can't find the holder you're looking for, please contact this office for assistance.



Table of Contents

Categorized Listing

BMT65	1
DRIVEN	1
RADIAL DRIVEN TOOL	1
GEARED-UP RADIAL DRIVEN TOOL REDIRECTED 36mm	1
RADIAL INVERTED DRIVEN TOOL 250mm INTERAXIS	2
AXIAL DRIVEN TOOL H=72mm	2
AXIAL DRIVEN TOOL H=100mm	3
AXIAL OPPOSITE FACE DRIVEN TOOL H=100mm	3
0-90 ADJUSTABLE ANGLE DRIVEN TOOL	4
GEAR HOBBER	5
GEAR HOBBER - HEAVY DUTY	5
STATIC	6
RADIAL STATIC HOLDER	6
RADIAL DOUBLE STATIC HOLDER	6
RADIAL DOUBLE BLADE HOLDER (CUT-OFF)	6
TAILSTOCK FOR SUBSPINDLE	7
AXIAL SINGLE BORING BAR HOLDER 100mm INTERAXIS	7
AXIAL SINGLE BORING BAR HOLDER	8
DOUBLE AXIAL BORING BAR HOLDER	8
BMT75	9
DRIVEN	9
RADIAL DRIVEN TOOL	9
RADIAL RE-DIRECTED DRIVEN TOOL	9
GEARED-UP RADIAL RE-DIRECTED DRIVEN TOOL	10
GEARED-UP RADIAL DRIVEN TOOL	10
RADIAL INVERTED DRIVEN TOOL	10
AXIAL DRIVEN TOOL	11
AXIAL REAR-SET DRIVEN TOOL	11
0-90 ADJUSTABLE ANGLE DRIVEN TOOL	12
0-180 ADJUSTABLE ANGLE DRIVEN TOOL	12
GEAR HOBBER	13
POLYGON MAKING MILL HEAD (3 INSERTS)	14
POLYGON MAKING MILL HEAD (2 INSERTS)	14
STATIC	15
RADIAL STATIC TOOL	15
AXIAL STATIC TOOL	15
AXIAL SINGLE BORING BAR HOLDER	16

BMT65

DRIVEN

RADIAL DRIVEN TOOL

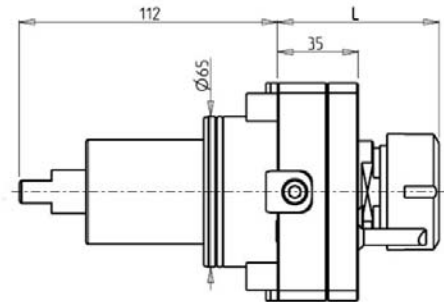
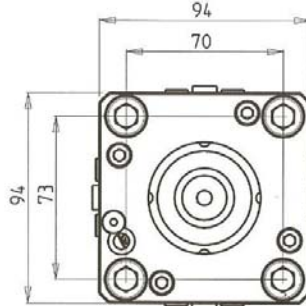
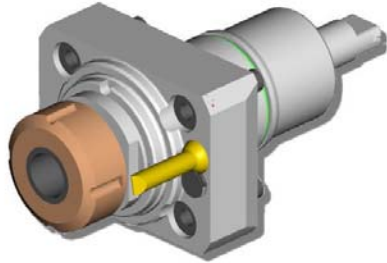

Part Number	Description	Spindle	I	RPM	Coolant Thru	Ext Coolant	L	Price
0281532	ER32 Standard	ER32	1:1	6000		X	70.06	\$2,075
0281032	ER32 Coolant Through *	ER32	1:1	6000	X		70.06	\$2,500
0280132	ER32A Standard	ER32A	1:1	6000		X	64.26	\$2,075
0280232	ER32A Coolant Through *	ER32A	1:1	6000	X		70.53	\$2,500

* Coolant Through tools are designed for 1000 psi.
They require 5 Micron Filtration and **CANNOT** be run dry.

GEARED-UP RADIAL DRIVEN TOOL REDIRECTED 36mm

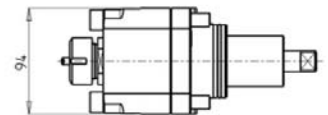
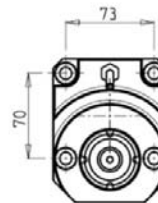
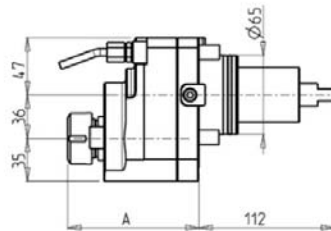
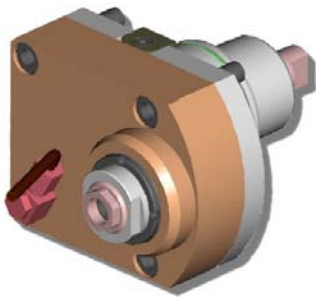

Part Number	Description	Spindle	I	RPM	Ext Coolant	A	Price
DWO 0140125	Geared-Up 1:2 Redirected 36mm ER25	ER25	1:2	12000	X	108.56	\$3,295

BMT65

DRIVEN

RADIAL INVERTED DRIVEN TOOL 250mm INTERAXIS

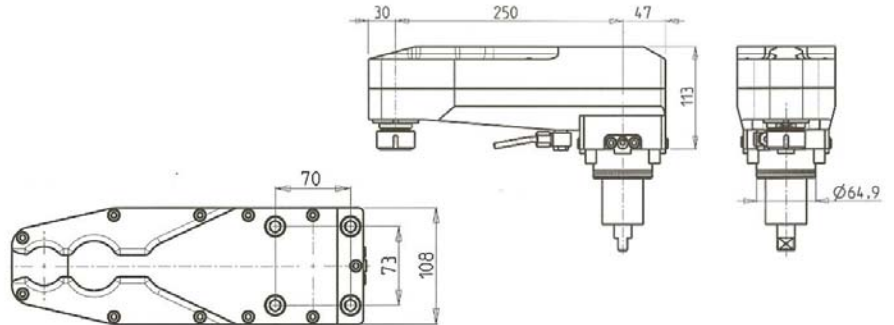
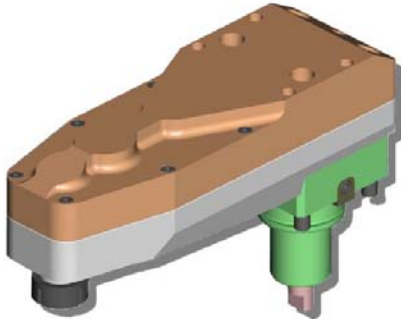

Part Number	Description	Reversible Main / Sub Spindle	Spindle	I	RPM	Ext Coolant	Price
0700025	Inverted 250mm Interaxis ER25	X	ER25	1:2	12000	X	\$7,195

AXIAL DRIVEN TOOL H=72mm

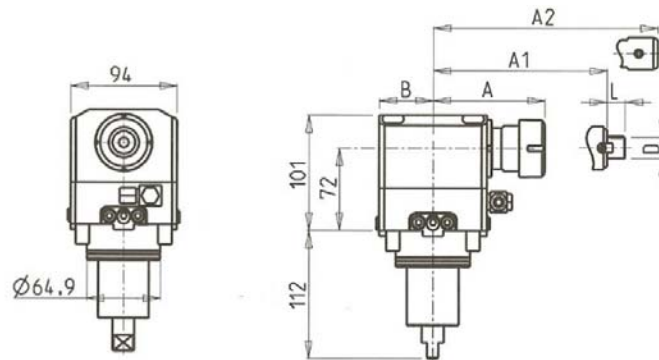

Part Number	Description	Spindle	RPM	Coolant Thru	Ext Coolant	A	A1	A2	B	D	L	Price
0321432	ER32 Standard	ER32	6000		X	98.16			47			\$3,200
0321032	ER32 Coolant Through *	ER32	6000	X	X	98.16			79			\$3,750
0320022	Weldon 20	Weldon 20	6000		X			100	47			\$3,450
0321617	Milling Head D=16mm, L=17mm	16x17	6000		X		61		47	16	17	\$3,450
0322219	Milling Head D=22mm, L=19mm	22x19	6000		X		62		47	22	19	\$3,450
0322240	Milling Head D=22mm, L=40mm	22x40	6000		X		62		47	22	40	\$3,450
0322721	Milling Head D=27mm, L=21mm	27x21	6000		X		64		47	27	21	\$3,500
0322733	Milling Head D=27mm, L=33mm	27x33	6000		X		64		47	27	33	\$3,500
0322750	Milling Head D=27mm, L=50mm	27x50	6000		X		64		47	27	50	\$3,500

* Coolant Through tools are designed for 1000 psi.
They require 5 Micron Filtration and **CANNOT** be run dry.

BMT65

DRIVEN

AXIAL DRIVEN TOOL H=100mm

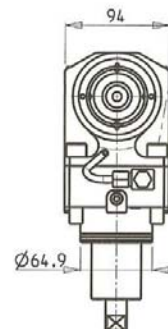
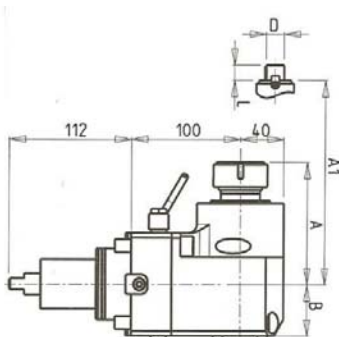
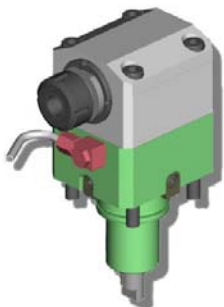

Part Number	Description	Spindle	RPM	Coolant Thru	Ext Coolant	A	A1	B	D	L	Price
0711432	ER32 Standard H=100mm	ER32	6000		X	111.56		47			\$3,650
0711032	ER32 Coolant Through * H=100mm	ER32	6000	X	X	111.56		72			\$4,000
0712640	ER40 Standard H=100mm	ER40	6000		X	115		47			\$3,600
0712540	ER40 Coolant Through * H=100mm	ER40	6000	X	X	115		72			\$4,000
0711617	Milling Head D=16mm, L=17mm H=100mm	16x17	6000		X		86	47	16	17	\$3,695
0712219	Milling Head D=22mm, L=19mm H=100mm	22x19	6000		X		86	47	22	19	\$3,695
0712240	Milling Head D=22mm, L=40mm H=100mm	22x40	6000		X		86	47	22	40	\$3,695
0712721	Milling Head D=27mm, L=21mm H=100mm	27x21	6000		X		87.5	47	27	21	\$3,695
0712733	Milling Head D=27mm, L=33mm H=100mm	27x33	6000		X		86	47	27	33	\$3,695
0712750	Milling Head D=27mm, L=50mm H=100mm	27x50	6000		X		86	47	27	50	\$3,695

* Coolant Through tools are designed for 1000 psi.
They require 5 Micron Filtration and **CANNOT** be run dry.

AXIAL OPPOSITE FACE DRIVEN TOOL H=100mm

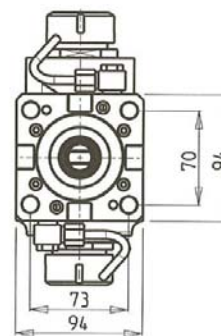
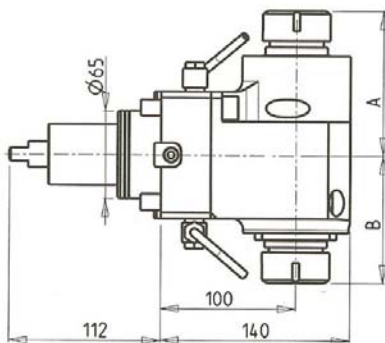

Part Number	Description	Reversible Main / Sub Spindle	Spindle	RPM	Ext Coolant	A	B	Price
DWO 0070232	Double Outlet ER32/ER32 Opposite Face	X	ER32+ER32	6000	X	107.66	94.26	\$4,175
DWO 0073225	Double Outlet ER25A/ER25A Opposite Face	X	ER25A+ER25A	6000	X	106.03	81.13	\$4,200

BMT65

DRIVEN

0-90 ADJUSTABLE ANGLE DRIVEN TOOL

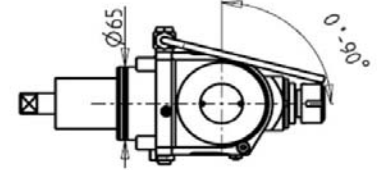
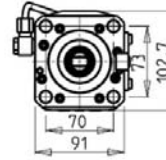
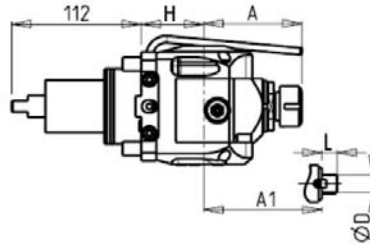

Part Number	Description	Reversible Main / Sub Spindle	Spindle	RPM	Ext Coolant	A	A1	D	H	L	Price
0370020	Adjustable Angle (0-90) ER20	X	ER20	6000	X	84.66			54		\$6,000
0370120	Adjustable Angle (0-90) ER20 H=100mm	X	ER20	6000	X	84.66			100		\$6,100
0370025	Adjustable Angle (0-90) ER25	X	ER25	6000	X	85.66			54		\$6,100
0370125	Adjustable Angle (0-90) ER25 H=100mm	X	ER25	6000	X	85.66			100		\$6,200
0371617	Adj. Angle (0-90) Milling Head D=16mm L=17mm	X	16x17	6000	X		65	16	54	17	\$6,200
0372617	Adj. Angle (0-90) Milling Head D=16mm L=17mm H=100mm	X	16x17	6000	X		65	16	100	17	\$6,300
0372219	Adj. Angle (0-90) Milling Head D=22mm L=19mm	X	22x19	6000	X		65	22	54	19	\$6,200
0373219	Adj. Angle (0-90) Milling Head D=22mm L=19mm H=100mm	X	22x19	6000	X		65	22	100	19	\$6,300
0371905	Adj. Angle (0-90) Milling Head D=3/4" L=3/4"	X	3/4"x3/4"	6000	X		65	3/4"	54	3/4"	\$6,200
0372905	Adj. Angle (0-90) Milling Head D=3/4" L=3/4" H=100mm	X	3/4"x3/4"	6000	X		65	3/4"	100	3/4"	\$6,300

Note : Wrenches are provided with the purchase of Specialty Toolholders

BMT65

DRIVEN

GEAR HOBBER

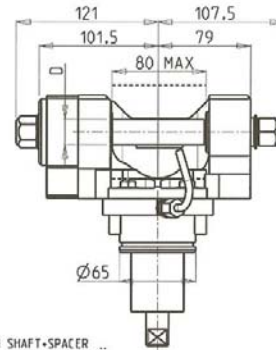
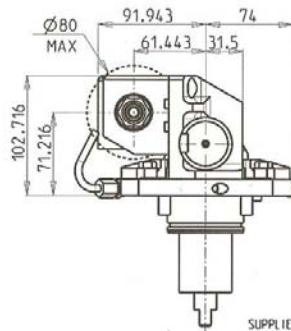
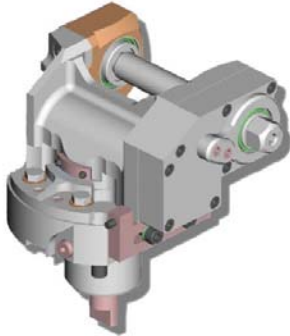

SUPPLIED WITH: N°1 SHAFT-SPACER ...

Part Number	Description	Reversible Main / Sub Spindle	I	RPM	Ext Coolant	D mm	D Inch	Price
0321100	Gear Hobbing Tool 1:1	X	1:1	6000	X	16-22-27-32	3/4"-1"-1 1/4"	\$7,900
0322100	Gear Hobbing Tool 2:1 Geared Down	X	2:1	3000	X	16-22-27-32	3/4"-1"-1 1/4"	\$7,995

Note :

Wrenches are provided with the purchase of Specialty Toolholders

GEAR HOBBER - HEAVY DUTY

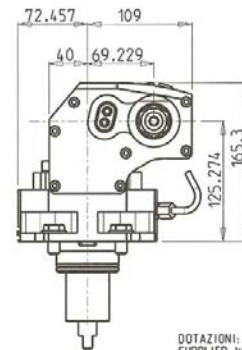
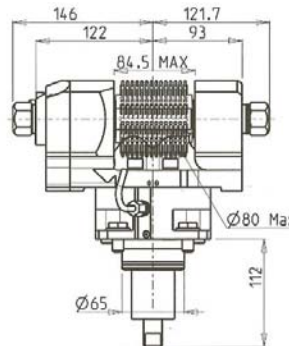
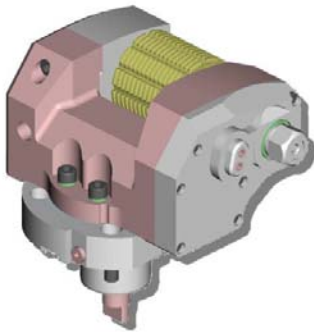

DOTAZIONI: A
C1001 IFR: M.1

Part Number	Description	Reversible Main / Sub Spindle	I	RPM	Ext Coolant	D mm	D Inch	Price
DWO 0031100	Heavy Duty Gear Hobbing Tool 1:1	X	1:1	6000	X	22-27-32	1"-1 1/4"	\$8,500
DWO 0032100	Heavy Duty Gear Hobbing Tool 2:1 Geared Down	X	2:1	3000	X	22-27-32	1"-1 1/4"	\$8,600

Note :

Wrenches are provided with the purchase of Specialty Toolholders

BMT65

STATIC

RADIAL STATIC HOLDER

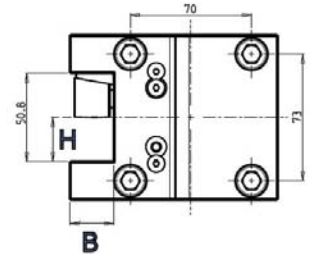
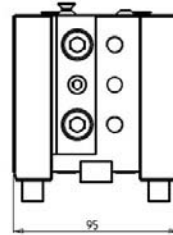
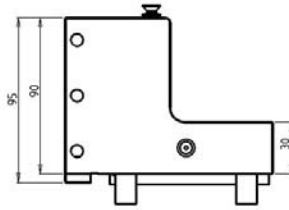
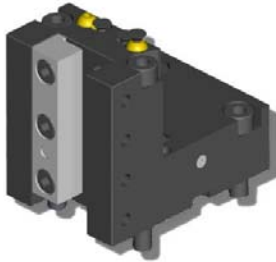

Part Number	Description	Number of Tools	Reversible Main / Sub Spindle	Dimensions	B	H	Price
DWO 0482540	Radial Static Tool : 1"	1	X	Inch	1"	1"	\$850

RADIAL DOUBLE STATIC HOLDER

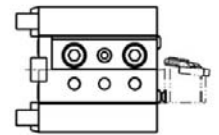
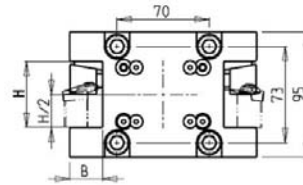
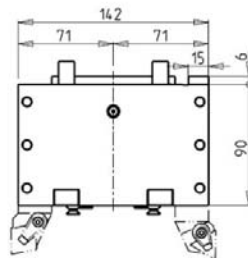
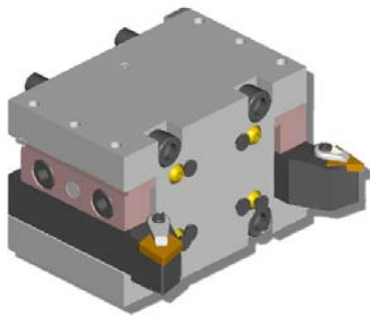

Part Number	Description	Number of Tools	Reversible Main / Sub Spindle	Dimensions	B	H	Price
DWO 0272540	Radial Double Static Tool : 1"	2	X	Inch	1"	2"	\$915
DWO 0272500	Radial Double Static Tool : 25mm	2	X	mm	25	50	\$915

RADIAL DOUBLE BLADE HOLDER (CUT-OFF)

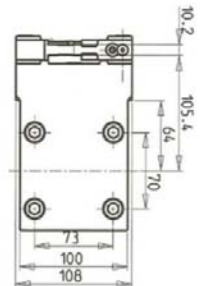
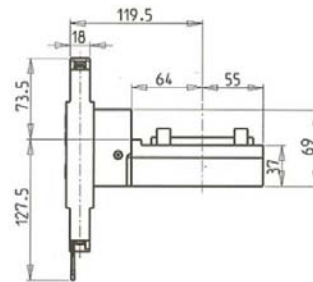
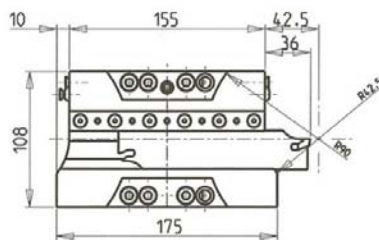
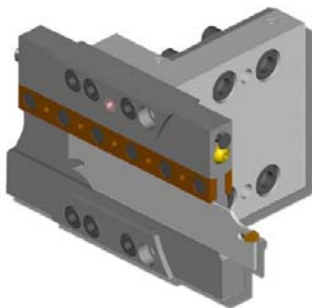

Part Number	Description	Price
DWO 0120132	Radial Double Blade Holder	\$995
BLADEKIT	Blade Kit: 1 Blade, 10 Inserts for DWO 0120132	\$170

BMT65

STATIC

TAILSTOCK FOR SUBSPINDLE

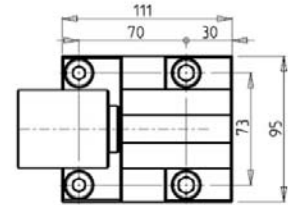
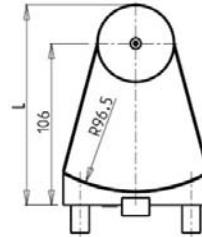
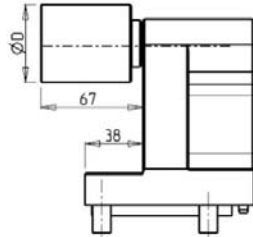
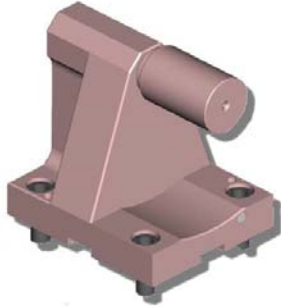

Part Number	Description	# of Tools	D	L	Price
0820200	Tailstock for Sub Spindle 38mm	1	38	125	\$795
0820200L	Tailstock for Sub Spindle 2"	1	2"	131.4	\$795

AXIAL SINGLE BORING BAR HOLDER 100mm INTERAXIS

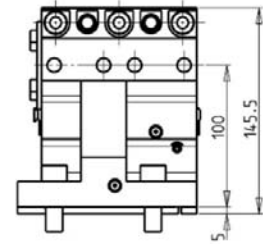
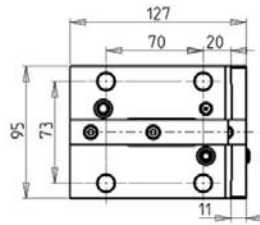
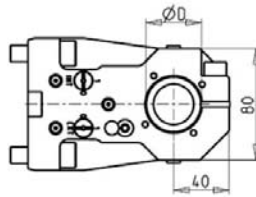

Part Number	Description	Number of Tools	Reversible Main/Sub Spindle	Coolant Thru	Ext Coolant	Dimensions	B	Price
DWO 0204000	Axial Single Boring Bar Holder 40mm 100mm Interaxis	1	X	OPTION	X	mm	40	\$895
KIT 1003003	Plug & Seal Kit to make 40mm BBH Coolant Through							\$90

BMT65

STATIC

AXIAL SINGLE BORING BAR HOLDER

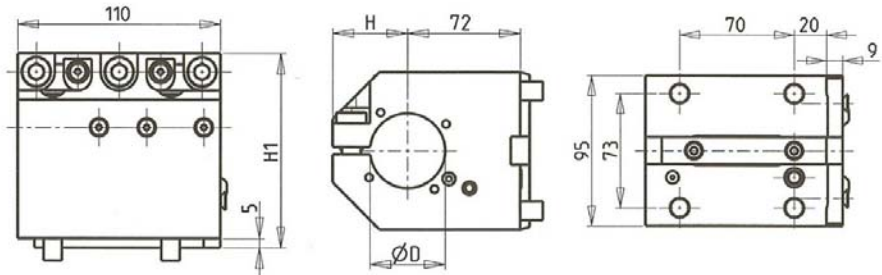
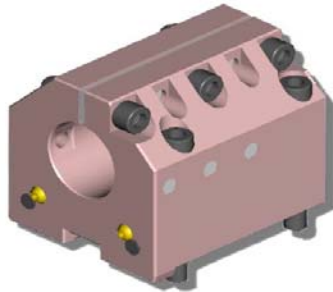

Part Number	Description	Number of Tools	Coolant Thru	Ext Coolant	Dimensions	D	H	H1	Price
0833810	Axial Single Boring Bar Holder : 1-1/2"	1	OPTION	X	Inch	1 1/2"	40	117.5	\$795
0835080	Axial Single Boring Bar Holder : 2"	1	OPTION	X	Inch	2	46.5	123.5	\$825
0834000	Axial Single Boring Bar Holder : 40mm	1	OPTION	X	mm	40	40	117.5	\$795
0835000	Axial Single Boring Bar Holder : 50mm	1	OPTION	X	mm	50	46.5	123.5	\$825
KIT 1003004	Plug & Seal Kit to make 1 1/2" BBH Coolant Through								\$90
KIT 1003003	Plug & Seal Kit to make 40mm BBH Coolant Through								\$90
KIT 1003002	Plug & Seal Kit to make 50mm or 2" BBH Coolant Through								\$90

DOUBLE AXIAL BORING BAR HOLDER

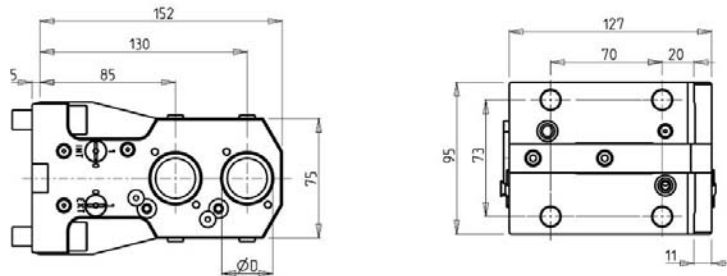
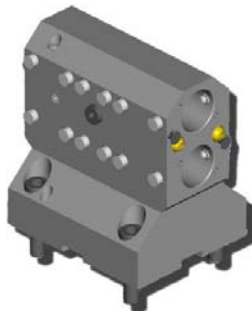

Part Number	Description	Number of Tools	Reversible Main/Sub Spindle	Coolant Thru	Ext Coolant	Dimensions	B	Price
DWO 0213200	Axial Double Boring Bar Holder 32mm	1	X	OPTION	X	mm	32	\$895
KIT 1000001	Plug for 32mm							\$69

BMT75

DRIVEN

RADIAL DRIVEN TOOL

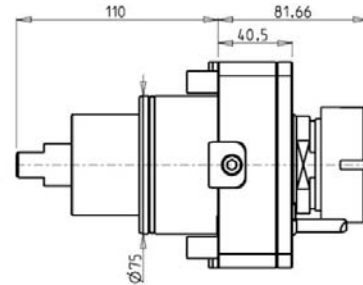
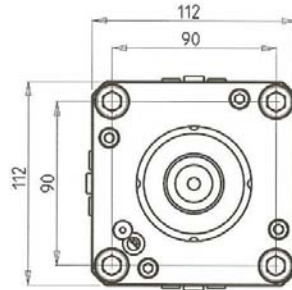
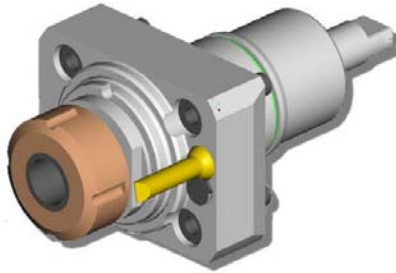

Part Number	Description	Spindle	RPM	Coolant Thru	Ext Coolant	Price
0291040	ER40 Coolant Through *	ER40	6000	X		\$2,700
0291540	ER40 Standard	ER40	6000		X	\$2,275

* Coolant Through tools are designed for 1000 psi.
They require 5 Micron Filtration and **CANNOT** be run dry.

RADIAL RE-DIRECTED DRIVEN TOOL

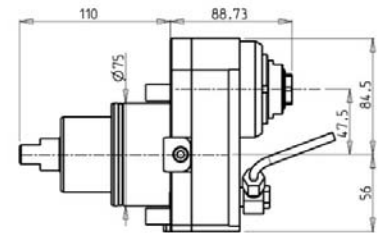
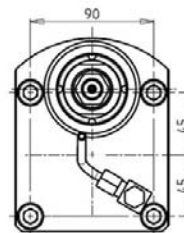
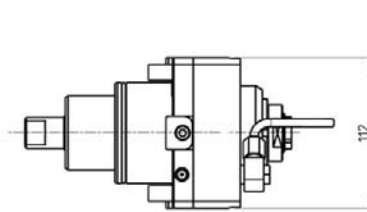

Part Number	Description	Spindle	I	RPM	Reversible Main/Sub Spindle	Ext Coolant	Price
DWO 0430120	Inverted Driven Tool	ER20A	1:1	6000	X	X	\$5,350

BMT75

DRIVEN

GEARED-UP RADIAL RE-DIRECTED DRIVEN TOOL

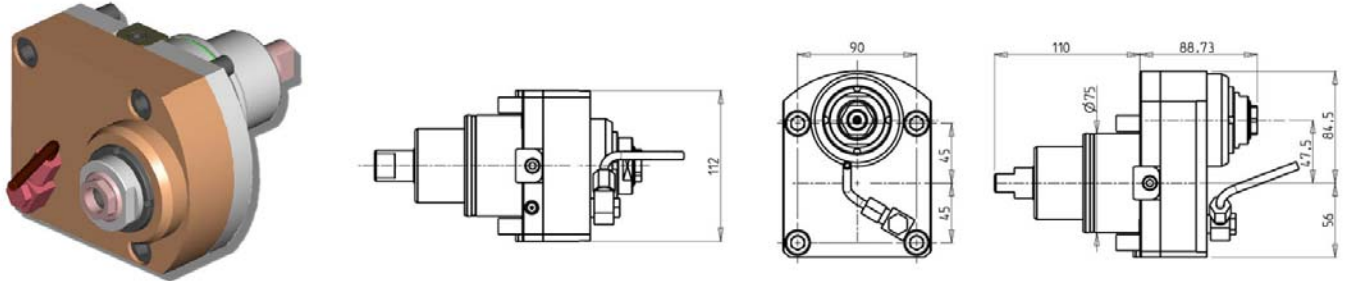

Part Number	Description	Spindle	I	RPM	Reversible Main/Sub Spindle	Ext Coolant	Price
DWO 0430220	Inverted Driven Tool	ER20A	1:2	12000	X	X	\$5,395

GEARED-UP RADIAL DRIVEN TOOL

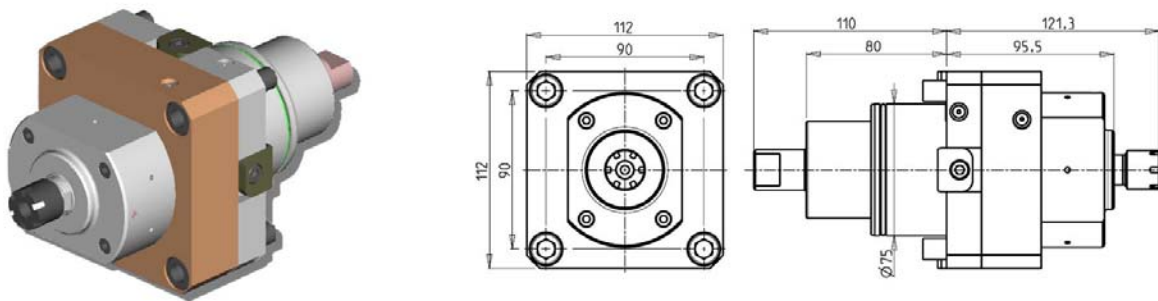

Part Number	Description	Spindle	I	RPM	Reversible Main/Sub Spindle	Coolant Thru	Price
DWO 0450116	Inverted Driven Tool	ER16	1:4	12000	X	X	\$4,595

RADIAL INVERTED DRIVEN TOOL

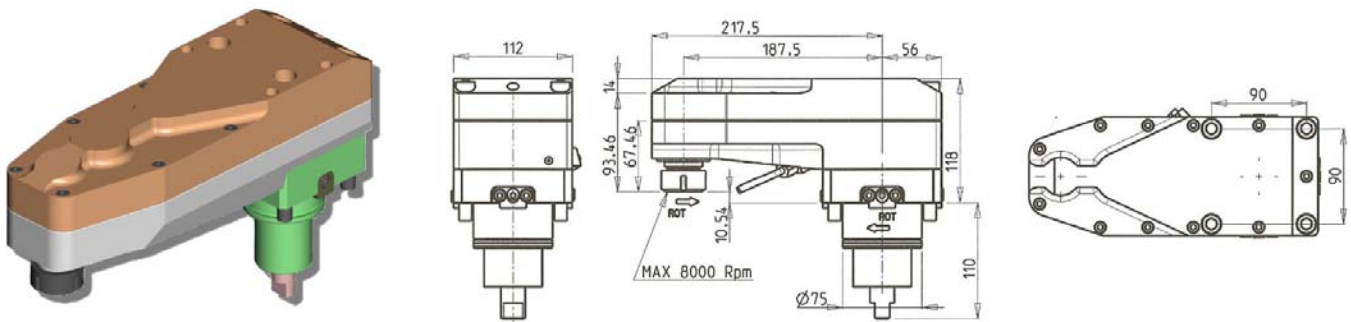

Part Number	Description	Spindle	RPM	Ext Coolant	Price
0841225	Inverted Driven Tool	ER25	8000	X	\$9,600

BMT75

DRIVEN

AXIAL DRIVEN TOOL

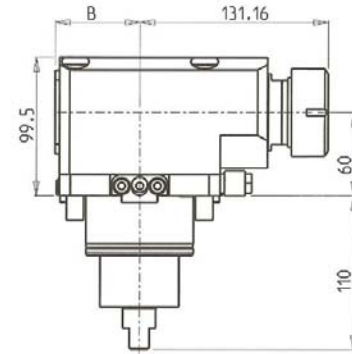
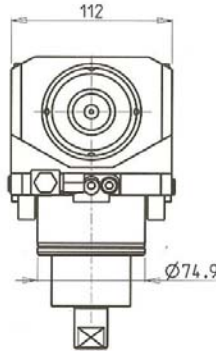
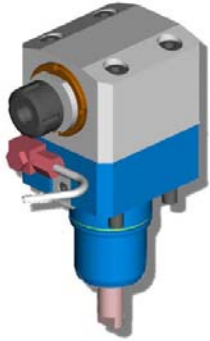

Part Number	Description	Spindle	RPM	Coolant Through	Ext Coolant	B	Price
0330840	ER40 Standard	ER40	6000		X	59	\$3,850
0331040	ER40 Coolant Through *	ER40	6000	X	X	85	\$4,900
0012721-0300075	Milling Head for Polygon Making D=27mm L=21mm	27x21	6000				\$5,975

* Coolant Through tools are designed for 1000 psi.
They require 5 Micron Filtration and **CANNOT** be run dry.

AXIAL REAR-SET DRIVEN TOOL

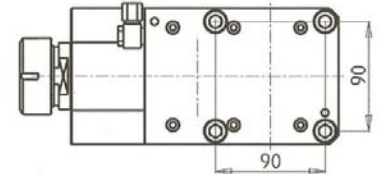
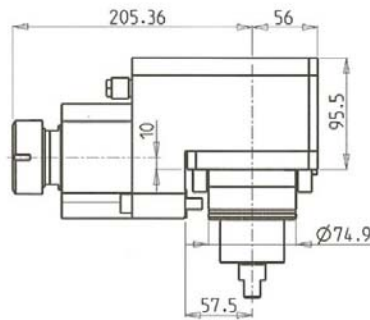
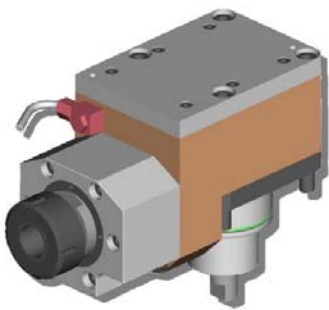

Part Number	Description	Spindle	RPM	Price
0350640	ER40 Rear-Set (-50mm) Driven Tool	ER40	6000	\$3,900

BMT75

DRIVEN

0-90 ADJUSTABLE ANGLE DRIVEN TOOL

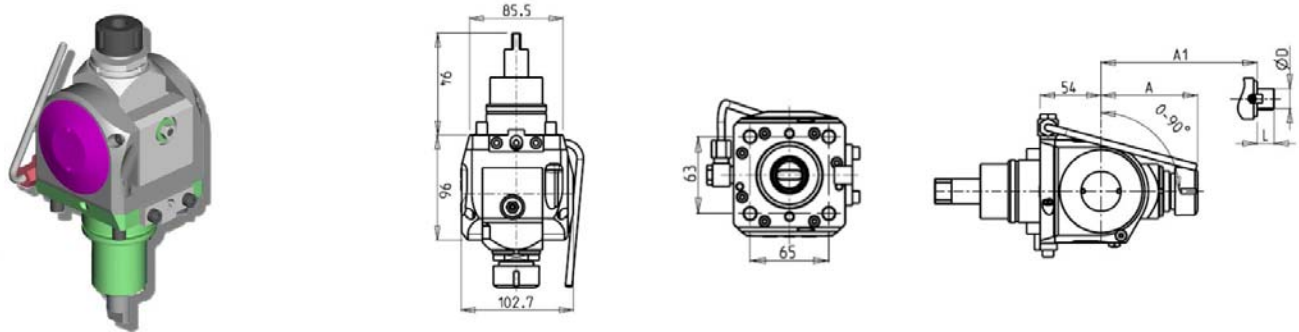

Part Number	Description	Reversible Main / Sub Spindle	Spindle	RPM	Ext Coolant	A	A1	D	L	Price
0200020-0300075	Adjustable Angle (0-90) ER20	X	ER20	6000	X	84.16				\$6,400
0200025-0300075	Adjustable Angle (0-90) ER25	X	ER25	6000	X	85.66				\$6,450
0201617-0300075	Adj. Angle (0-90) Milling Head D=16mm L=17mm	X	16x17	6000	X		65	16	17	\$6,500
0202219-0300075	Adj. Angle (0-90) Milling Head D=22mm L=19mm	X	22x19	6000	X		66	22	19	\$6,500
0201905-0300075	Adj. Angle (0-90) Milling Head D=3/4" L=3/4"	X	3/4" 3/4"	6000	X		65	3/4"	3/4"	\$6,500

Note : Wrenches are provided with the purchase of Specialty Toolholders

0-180 ADJUSTABLE ANGLE DRIVEN TOOL

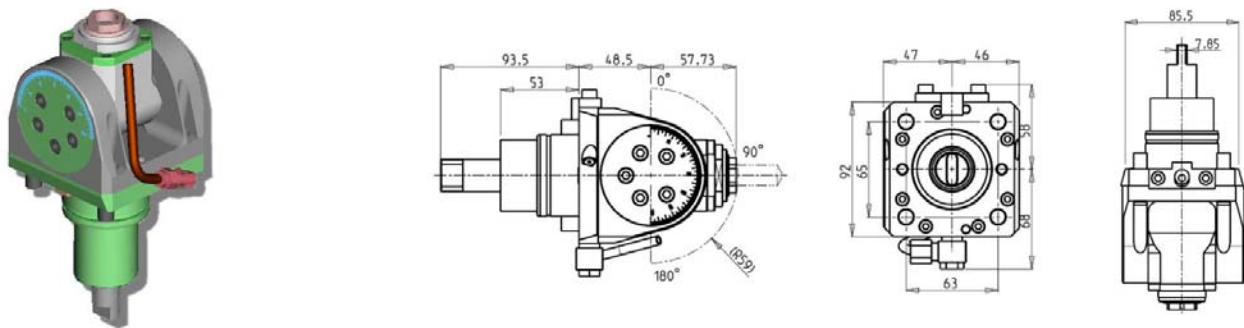

Part Number	Description	Reversible Main / Sub Spindle	Spindle	RPM	Ext Coolant	Price
0680020-0300075	0-180 Adjustable Angle ER20A Driven Tool	X	ER20A	6000	X	\$6,500

Note : Wrenches are provided with the purchase of Specialty Toolholders

BMT75

DRIVEN

GEAR HOBBER

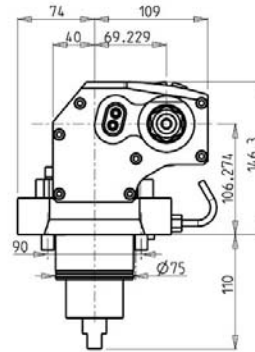
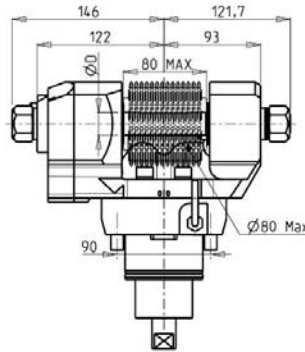
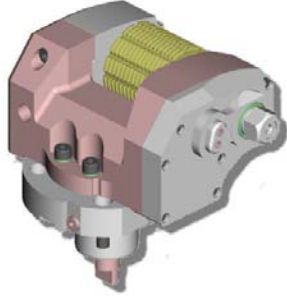

Part Number	Description	Reversible Main / Sub Spindle	RPM	Ext Coolant	D mm	D Inch	Price
DWO0251100	Gear Hobbing Tool 1:1	X	6000	X	16-22-27-32	3/4"-1"-1 1/4"	\$8,100
DWO0252100	Gear Hobbing Tool 2:1 Geared Down	X	3000	X	16-22-27-32	3/4"-1"-1 1/4"	\$8,200

Note :

Wrenches are provided with the purchase of Specialty Toolholders

BMT75

DRIVEN

POLYGON MAKING MILL HEAD (3 INSERTS)

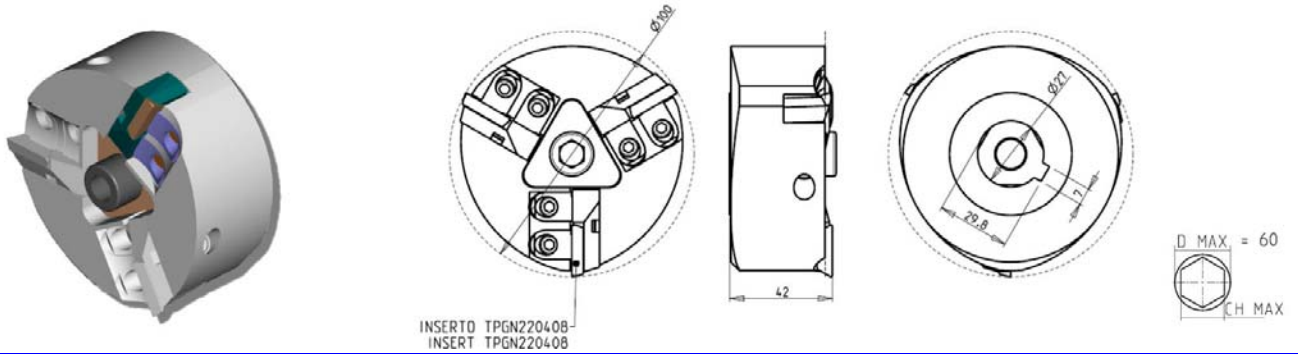

Part Number	Description	Price
P01Z30A100	3-Insert Polygon Making Head (with Inserts)	\$1,495
TPGN220408	10 Inserts for Polygon Making Heads	\$90

Note: These Polygon Making Mill Heads are for use with our Axial Tool #0012721-0300075

POLYGON MAKING MILL HEAD (2 INSERTS)

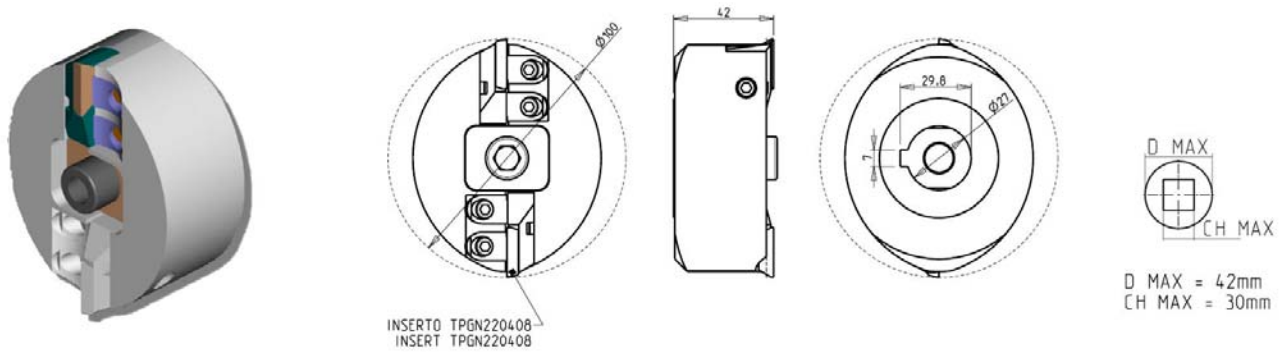

Part Number	Description	Price
P01Z20A100	2-Insert Polygon Making Head (with Inserts)	\$1,450
TPGN220408	10 Inserts for Polygon Making Heads	\$90

Note: These Polygon Making Mill Heads are for use with our Axial Tool #0012721-0300075

BMT75

STATIC

RADIAL STATIC TOOL

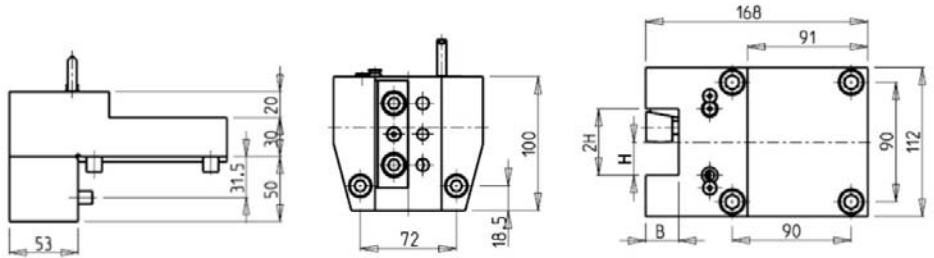
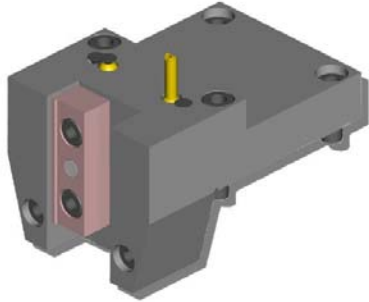

Part Number	Description	Number of Tools	Dimensions	B	H	Price
0902540	Radial Static Tool 1" x 1"	1	Inch	1"	1"	\$940
0903175	Radial Static Tool 1 1/4" x 1 1/4"	1	Inch	1 1/4"	1 1/4"	\$960
0902500	Radial Static Tool 25mm x 25 mm	1	mm	25	25	\$940
0903200	Radial Static Tool 32mm x 32mm	1	mm	32	32	\$960

AXIAL STATIC TOOL

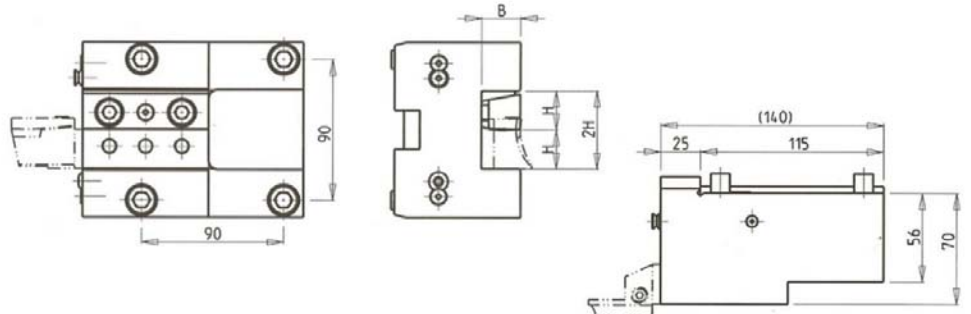
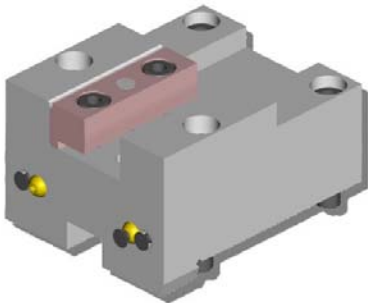

Part Number	Description	Number of Tools	Reversible Main / Sub Spindle	Dimensions	B	H	Price
0912540	Axial Static Tool 1" x 1"	1	X	Inch	1"	1"	\$1,075
0913175	Axial Static Tool 1 1/4" x 1 1/4"	1	X	Inch	1 1/4"	1 1/4"	\$1,095
0912500	Axial Static Tool 25mm x 25mm	1	X	mm	25	25	\$1,075
0913200	Axial Static Tool 32mm x 32mm	1	X	mm	32	32	\$1,095

BMT75

STATIC

AXIAL SINGLE BORING BAR HOLDER

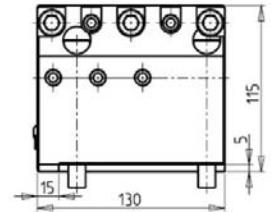
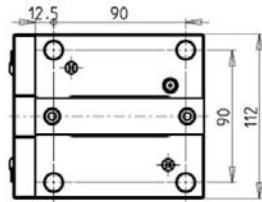

Part Number	Description	Number of Tools	Reversible Main/Sub Spindle	Coolant Through	Ext Coolant	Dimensions	D	Price
DWO 0363810	Axial Boring Bar Holder 1 1/2"	1	X	OPTION	X	Inch	1 1/2"	\$995
DWO 0365080	Axial Boring Bar Holder 2.0"	1	X	OPTION	X	Inch	2.0"	\$995
DWO 0364000	Axial Boring Bar Holder 40mm	1	X	OPTION	X	mm	40	\$995
DWO 0365000	Axial Boring Bar Holder 50mm	1	X	OPTION	X	mm	50	\$995
KIT 1001002	Plug & Seal Kit to Make 50mm or 2" BBH Coolant Through							\$90
KIT 1001003	Plug & Seal Kit to Make 40mm BBH Coolant Through							\$90
KIT 1001004	Plug & Seal Kit to Make 1-1/2" BBH Coolant Through							\$90

ER COLLETS : SETS AND INDIVIDUAL

High Precision and Sealed for Coolant Through (1000 PSI) Applications
Available in Inch and Metric

.0002" ACCURACY

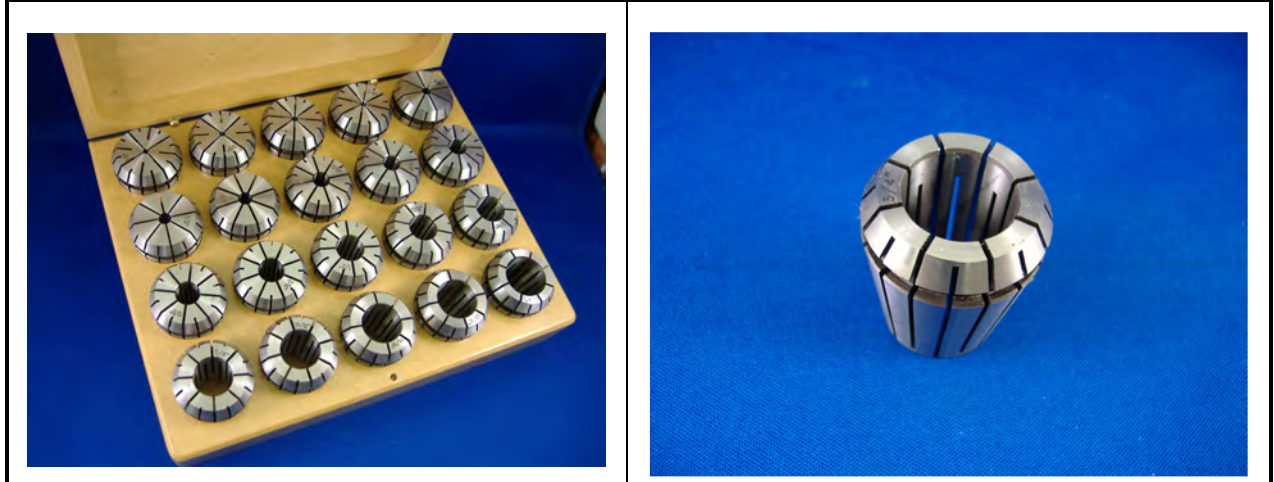

INCH SIZES	ER 25	ER 25 SEALED	ER 32	ER 32 SEALED	ER 40	ER 40 SEALED
1/16	ERX25-001					
3/32	ERX25-002		ERX32-001			
1/8	ERX25-003	ERXG25-001	ERX32-002	ERXG32-001	ERX40-001	
3/16	ERX25-004	ERXG25-002	ERX32-003	ERXG32-002	ERX40-002	ERXG40-001
7/32	ERX25-005	ERXG25-003	ERX32-004	ERXG32-003	ERX40-003	ERXG40-002
1/4	ERX25-006	ERXG25-004	ERX32-005	ERXG32-004	ERX40-004	ERXG40-003
5/16	ERX25-007	ERXG25-005	ERX32-006	ERXG32-005	ERX40-005	ERXG40-004
11/32	ERX25-008	ERXG25-006	ERX32-007	ERXG32-006	ERX40-006	ERXG40-005
3/8	ERX25-009	ERXG25-007	ERX32-008	ERXG32-007	ERX40-007	ERXG40-006
13/32	ERX25-010	ERXG25-008	ERX32-009	ERXG32-008	ERX40-008	ERXG40-007
7/16	ERX25-011	ERXG25-009	ERX32-010	ERXG32-009	ERX40-009	ERXG40-008
1/2	ERX25-012	ERXG25-010	ERX32-011	ERXG32-010	ERX40-010	ERXG40-009
17/32	ERX25-013	ERXG25-011	ERX32-012	ERXG32-011	ERX40-011	ERXG40-010
9/16	ERX25-014	ERXG25-012	ERX32-013	ERXG32-012	ERX40-012	ERXG40-011
5/8	ERX25-015	ERXG25-013	ERX32-014	ERXG32-013	ERX40-013	ERXG40-012
21/32			ERX32-015	ERXG32-014	ERX40-014	ERXG40-013
11/16			ERX32-016	ERXG32-015	ERX40-015	ERXG40-014
23/32			ERX32-017	ERXG32-016		
3/4			ERX32-018	ERXG32-017	ERX40-016	ERXG40-015
25/32					ERX40-017	ERXG40-016
13/16					ERX40-018	ERXG40-017
27/32					ERX40-019	ERXG40-018
7/8					ERX40-020	ERXG40-019
15/16					ERX40-021	ERXG40-020
31/32					ERX40-022	ERXG40-021
1.00					ERX40-023	ERXG40-022
SET	ERX25-SET	ERXG25-SET	ERX32-SET	ERXG32-SET	ERX40-SET	ERXG40-SET

ER COLLETS

ER COLLET NUMBER	DESCRIPTION	MD LIST PRICE
ERX25-001 thru ERX25-015	ER25 Collet	\$ 21.00
ERX25-SET	ER25 Collet Set (15 Collets)	\$ 245.00
ERXG25-001 thru ERXG25-013	ER25 Sealed Collet	\$ 43.00
ERXG25-SET	ER25 Sealed Collet Set (13 Collets)	\$ 450.00
ERX32-001 thru ERX32-018	ER32 Collet	\$ 23.50
ERX32-SET	ER32 Collet Set (18 Collets)	\$ 310.00
ERXG32-001 thru ERXG32-017	ER32 Sealed Collet	\$ 46.50
ERXG32-SET	ER32 Sealed Collet Set (17 Collets)	\$ 625.00
ERX40-001 thru ERX40-023	ER40 Collet	\$ 28.50
ERX40-SET	ER40 Collet Set (23 Collets)	\$ 540.00
ERXG40-001 thru ERXG40-022	ER40 Sealed Collet	\$ 48.00
ERXG40-SET	ER40 Sealed Collet Set (22 Collets)	\$ 875.00

LIVE TOOL WRENCHES

WRENCH NUMBER	DESCRIPTION	MD LIST PRICE
From Catalog Above	ER Collet Wrench (Identify Holder)	\$ 22.00
From Catalog Above	Spindle Locking Wrench (Identify Holder)	\$ 22.00

Table of Contents

Part Number Index

O

0012721-0300075	Milling Head for Polygon Making D=27mm L=21mm	11
0200020-0300075	Adjustable Angle (0-90) ER20	12
0200025-0300075	Adjustable Angle (0-90) ER25	12
0201617-0300075	Adj. Angle (0-90) Milling Head D=16mm L=17mm	12
0201905-0300075	Adj. Angle (0-90) Milling Head D=3/4" L=3/4"	12
0202219-0300075	Adj. Angle (0-90) Milling Head D=22mm L=19mm	12
0280132	ER32A Standard	1
0280232	ER32A Coolant Through *	1
0281032	ER32 Coolant Through *	1
0281532	ER32 Standard	1
0291040	ER40 Coolant Through *	9
0291540	ER40 Standard	9
0320022	Weldon 20	2
0321032	ER32 Coolant Through *	2
0321100	Gear Hobbing Tool 1:1	5
0321432	ER32 Standard	2
0321617	Milling Head D=16mm, L=17mm	2
0322100	Gear Hobbing Tool 2:1 Geared Down	5
0322219	Milling Head D=22mm, L=19mm	2
0322240	Milling Head D=22mm, L=40mm	2
0322721	Milling Head D=27mm, L=21mm	2
0322733	Milling Head D=27mm, L=33mm	2
0322750	Milling Head D=27mm, L=50mm	2
0330840	ER40 Standard	11
0331040	ER40 Coolant Through *	11
0350640	ER40 Rear-Set (-50mm) Driven Tool	11
0370020	Adjustable Angle (0-90) ER20	4
0370025	Adjustable Angle (0-90) ER25	4
0370120	Adjustable Angle (0-90) ER20 H=100mm	4
0370125	Adjustable Angle (0-90) ER25 H=100mm	4
0371617	Adj. Angle (0-90) Milling Head D=16mm L=17mm	4
0371905	Adj. Angle (0-90) Milling Head D=3/4" L=3/4"	4
0372219	Adj. Angle (0-90) Milling Head D=22mm L=19mm	4
0372617	Adj. Angle (0-90) Milling Head D=16mm L=17mm H=100mm	4
0372905	Adj. Angle (0-90) Milling Head D=3/4" L=3/4" H=100mm	4
0373219	Adj. Angle (0-90) Milling Head D=22mm L=19mm H=100mm	4
0680020-0300075	0-180 Adjustable Angle ER20A Driven Tool	12
0700025	Inverted 250mm Interaxis ER25	2
0711032	ER32 Coolant Through * H=100mm	3
0711432	ER32 Standard H=100mm	3
0711617	Milling Head D=16mm, L=17mm H=100mm	3
0712219	Milling Head D=22mm, L=19mm H=100mm	3
0712240	Milling Head D=22mm, L=40mm H=100mm	3
0712540	ER40 Coolant Through * H=100mm	3
0712640	ER40 Standard H=100mm	3
0712721	Milling Head D=27mm, L=21mm H=100mm	3
0712733	Milling Head D=27mm, L=33mm H=100mm	3
0712750	Milling Head D=27mm, L=50mm H=100mm	3
0820200	Tailstock for Sub Spindle 38mm	7
0820200L	Tailstock for Sub Spindle 2"	7
0833810	Axial Single Boring Bar Holder : 1-1/2"	8
0834000	Axial Single Boring Bar Holder : 40mm	8
0835000	Axial Single Boring Bar Holder : 50mm	8
0835080	Axial Single Boring Bar Holder : 2"	8
0841225	Inverted Driven Tool	10
0902500	Radial Static Tool 25mm x 25 mm	15
0902540	Radial Static Tool 1" x 1"	15
0903175	Radial Static Tool 1 1/4" x 1 1/4"	15
0903200	Radial Static Tool 32mm x 32mm	15
0912500	Axial Static Tool 25mm x 25mm	15
0912540	Axial Static Tool 1" x 1"	15
0913175	Axial Static Tool 1 1/4" x 1 1/4"	15
0913200	Axial Static Tool 32mm x 32mm	15

B

BLADEKIT	Blade Kit: 1 Blade, 10 Inserts for DW0 0120132	6
----------	--	---

D

DW0 0031100	Heavy Duty Gear Hobbing Tool 1:1	5
DW0 0032100	Heavy Duty Gear Hobbing Tool 2:1 Geared Down	5
DW0 0070232	Double Outlet ER32/ER32 Opposite Face	3
DW0 0073225	Double Outlet ER25A/ER25A Opposite Face	3
DW0 0120132	Radial Double Blade Holder	6
DW0 0140125	Geared-Up 1:2 Redirected 36mm ER25	1
DW0 0204000	Axial Single Boring Bar Holder 40mm 100mm Interaxis	7
DW0 0213200	Axial Double Boring Bar Holder 32mm	8
DW0 0272500	Radial Double Static Tool : 25mm	6
DW0 0272540	Radial Double Static Tool : 1"	6
DW0 0363810	Axial Boring Bar Holder 1 1/2"	16
DW0 0364000	Axial Boring Bar Holder 40mm	16
DW0 0365000	Axial Boring Bar Holder 50mm	16
DW0 0365080	Axial Boring Bar Holder 2.0"	16
DW0 0430120	Inverted Driven Tool	9
DW0 0430220	Inverted Driven Tool	10
DW0 0450116	Inverted Driven Tool	10
DW0 0482540	Radial Static Tool : 1"	6
DW00251100	Gear Hobbing Tool 1:1	13
DW00252100	Gear Hobbing Tool 2:1 Geared Down	13

K

KIT 1000001	Plug for 32mm	8
KIT 1001002	Plug & Seal Kit to Make 50mm or 2" BBH Coolant Through	16
KIT 1001003	Plug & Seal Kit to Make 40mm BBH Coolant Through	16
KIT 1001004	Plug & Seal Kit to Make 1-1/2" BBH Coolant Through	16
KIT 1003002	Plug & Seal Kit to make 50mm or 2" BBH Coolant Through	8
KIT 1003003	Plug & Seal Kit to make 40mm BBH Coolant Through	7
KIT 1003003	Plug & Seal Kit to make 40mm BBH Coolant Through	8
KIT 1003004	Plug & Seal Kit to make 1 1/2" BBH Coolant Through	8

P

P01Z20A100	2-Insert Polygon Making Head (with Inserts)	14
P01Z30A100	3-Insert Polygon Making Head (with Inserts)	14

T

TPGN220408	10 Inserts for Polygon Making Heads	14
TPGN220408	10 Inserts for Polygon Making Heads	14