

DRIVEN and STATIC TOOLING

For

Okuma Lathes

LB2000EX, LB3000EX



10139 BERGIN RD.

HOWELL, MI 48843

PHONE : 877-91-TOOLS (810-632-4446)

FAX: 877-92-TOOLS (810-632-4467)

EMAIL: info@mdtooling.com

WEBSITE: www.mdtooling.com

June 2009

Live Tooling

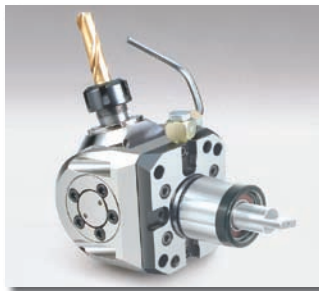

Live Tool Technology

M. T. Marchetti, a major live tool manufacture in northern Italy, is a leader in live tool technology. The formula is simple. Use only the best angular contact high-speed bearings available. Add to this exacting tolerances for all ground shafts, gears and bearing pocket features. Next, develop a sealed system that **will not** allow any contamination from chips or coolant.

Top this all off with a superior design and you end up with a live tool that is more rigid, faster and will last longer. **We back this up with a 2-Year factory warranty.**

Our Live Tool Warranty

Our tooling will give years of service in the most demanding applications. The superior design and rugged construction has proven this over the last 12 years. The reliability of our tools allows us to provide a 2-year factory warranty.

MD TOOLING will repair any defective tool holders for a period of 2 years from the date of purchase.

Product Range

We have the largest range of live tooling available for most major machine tool manufactures.

Our available products include an extensive line of standard live tooling as well as specialty toolholders such as 0-90 and 0-180 adjustable angle tool holders, gear hobbers, and even worm gear generators. Our product range includes geared up holders to 60,000 RPM and are engineered for 1,000 PSI coolant through.

We are an industry leader in providing complete tooling solutions with hundreds of static tool options as well.

Technical Support

Here at MD Tooling we have a full technical support department with over 25 years of CNC experience.

Our highly qualified staff can help with part processing, tooling up a job from a blue print and even assist with part programming. Applications Engineers are always available by phone to answer any questions you may have about our tooling or any other CNC related issue.

Stock and Replenishment

MD Tooling maintains an extensive inventory of tooling in our warehouse in Michigan. Our current "fill" rate on orders is 93% from our stock in Michigan for same day shipping.

Should you require a non-stock item, our manufacturer, M.T. Marchetti also maintains a large inventory in Italy. Tooling can be obtained in as little as 3-5 business days.

Shipping

MD Tooling realizes that when you need tooling, often you can't wait until the next day. We process orders and ship from available stock right up until 5PM EST to make certain we get your tooling solutions to you as quickly as possible.

We regularly ship throughout the day via DHL, UPS, FedEx or any other carrier that a customer requests.



10139 Bergin Road

Howell, MI 48843

Phone: 810 632-4446

Fax: 810 632-4467

Email: info@mdtooling.com

Web: www.mdtooling.com

- 2-Year Warranty on all live tools.
- Quality tooling at highly competitive pricing.
- Extensive inventory. We currently ship over 93% of all orders same day.
- Fast, Friendly, Reliable Service!
- More specialty tool holders than any other manufacturer.
- Custom tool holders available.
- All available tooling may not be shown in this catalog. If you can't find the holder you're looking for, please contact this office for assistance.



Table of Contents

Categorized Listing

LB2000EX - LB3000EX	1
DRIVEN	1
RADIAL DRIVEN TOOL	1
AXIAL DRIVEN TOOL	2
AXIAL OPPOSITE FACE DRIVEN TOOL	2
POLYGON MAKING MILL HEAD (3 INSERTS)	3
POLYGON MAKING MILL HEAD (2 INSERTS)	3
STATIC	4
RADIAL SINGLE TOOL STATIC HOLDER	4
RADIAL SINGLE SIDE DOUBLE TOOL STATIC HOLDER	4
RADIAL DOUBLE SIDE STATIC HOLDER	5
RADIAL BLADE HOLDER	5
AXIAL SINGLE STATIC TOOL HOLDER	6
AXIAL DOUBLE STATIC TOOL HOLDER	6
AXIAL SINGLE BORING BAR HOLDER	7
AXIAL DOUBLE BORING BAR HOLDER	7
AXIAL 4+4 POSITION BORING BAR HOLDER	8

LB2000EX - LB3000EX

DRIVEN

RADIAL DRIVEN TOOL

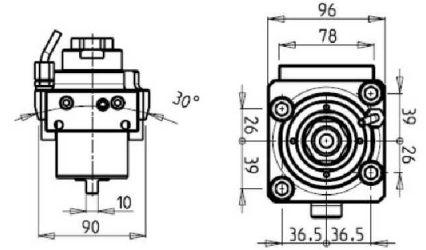
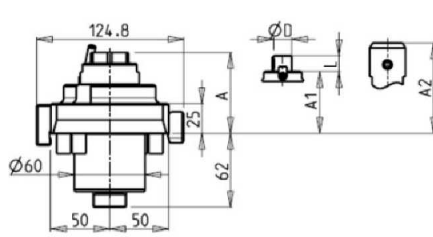
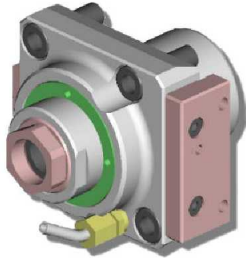

PartNumber	Description	Spindle	I	RPM	Coolant Thru	Ext Coolant	A	A1	A2	D	L
OKU0070132	ER32A Standard	ER32A	1:1	6000		X	68.03				
OKU0070232	ER32A Coolant Through *	ER32A	1:1	6000	X	X	78.03				
OKU0072519	Milling Head D=1", L=19mm	1"x19	1:1	6000		X		54.5		1"	19
OKU0071617	Milling Head D=16mm, L=17mm	16x17	1:1	6000		X		51.5		16	17
OKU0072219	Milling Head D=22mm, L=19mm	22x19	1:1	6000		X		53.5		22	19
OKU0072721	Milling Head D=27mm, L=21mm	27x21	1:1	6000		X		54.5		27	21
OKU0070320	Weldon 20 Standard	Weldon 20	1:1	6000		X			75.5		
OKU0070420	Weldon 20 Coolant Through *	Weldon 20	1:1	6000	X	X			85.5		

* Coolant Through tools are designed for 1000 psi.
They require 5 Micron Filtration and **CANNOT** be run dry.

LB2000EX - LB3000EX

DRIVEN

AXIAL DRIVEN TOOL

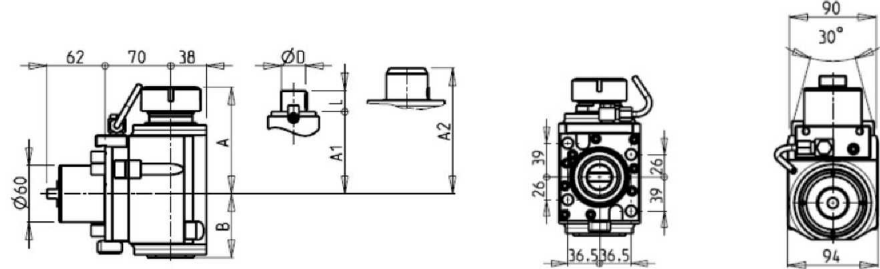
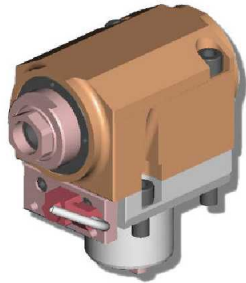

PartNumber	Description	Reversible Main / Sub Spindle	Spindle	I	RPM	Cool Thru	Ext Cool	A	A1	A2	B	D	L
OKU0060332	ER32 Standard	X	ER32	1:1	6000		X	110.66			67.5		
OKU0060432	ER32 Coolant Through *	X	ER32	1:1	6000	X	X	110.66			91		
OKU0060132	ER32A Standard	X	ER32A	1:1	6000		X	98.53			67.5		
OKU0060232	ER32A Coolant Through *	X	ER32A	1:1	6000	X	X	98.53			91		
OKU0060340	ER40 Standard	X	ER40	1:1	6000		X	113.16			67.5		
OKU0060440	ER40 Coolant Through *	X	ER40	1:1	6000	X	X	113.16			91		
OKU0061617	Milling Head D=16mm, L=17mm	X	16x17	1:1	6000		X		87.5		67.5	16	17
OKU0062219	Milling Head D=22mm, L=19mm	X	22x19	1:1	6000		X		87.5		67.5	22	19
OKU0062721	Milling Head D=27mm, L=21mm	X	27x21	1:1	6000		X		87.5		67.5	27	21
OKU0062519	Milling Head D=1", L=19mm	X	1"x19	1:1	6000		X		87.5		67.5	1"	19
OKU0060520	Weldon 20 Standard	X	Weldon 20	1:1	6000		X			105.5	67.5		
OKU0060620	Weldon 20 Coolant Through *	X	Weldon 20	1:1	6000	X	X			105.5	91		

* Coolant Through tools are designed for 1000 psi.

They require 5 Micron Filtration and **CANNOT** be run dry.

AXIAL OPPOSITE FACE DRIVEN TOOL

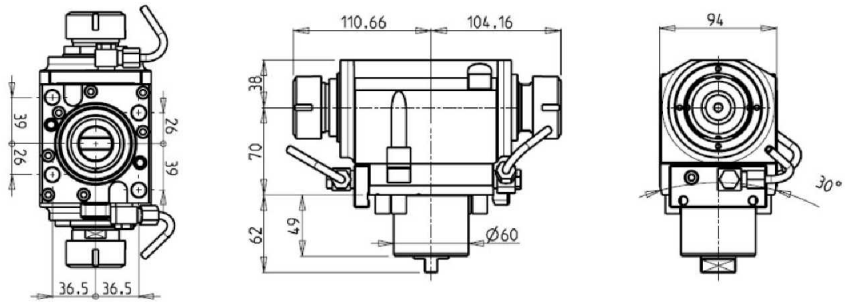
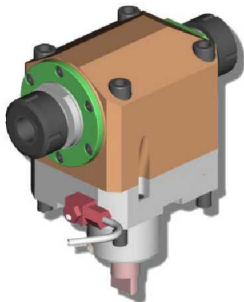

PartNumber	Description	Spindle	I	RPM	Ext Coolant
OKU0200232	Double Outlet ER32 / ER32 Opposite Face	ER32+ER32	1:1	6000	X

LB2000EX - LB3000EX

DRIVEN

POLYGON MAKING MILL HEAD (3 INSERTS)

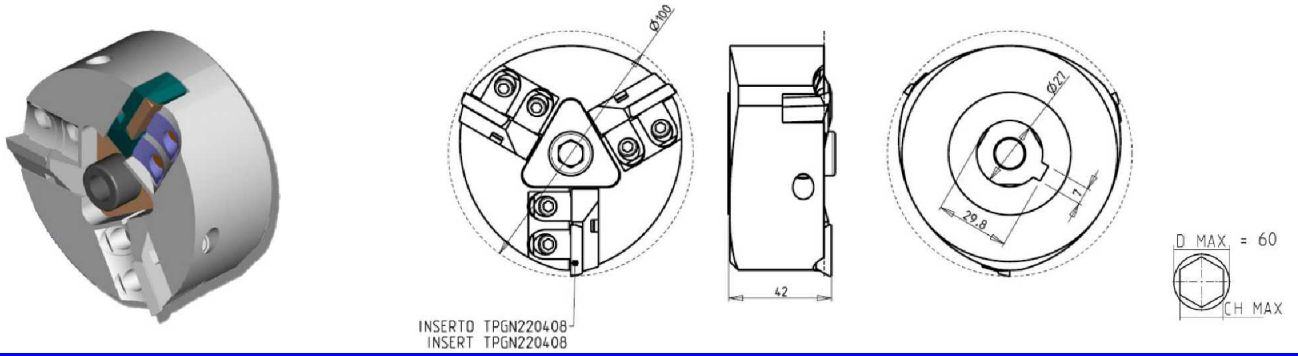

PartNumber	Description
P01Z30A100	3 Insert Polygon Making Mill Head (with Inserts)
TPGN220408	10 Inserts for Polygon Making Mill Heads

POLYGON MAKING MILL HEAD (2 INSERTS)

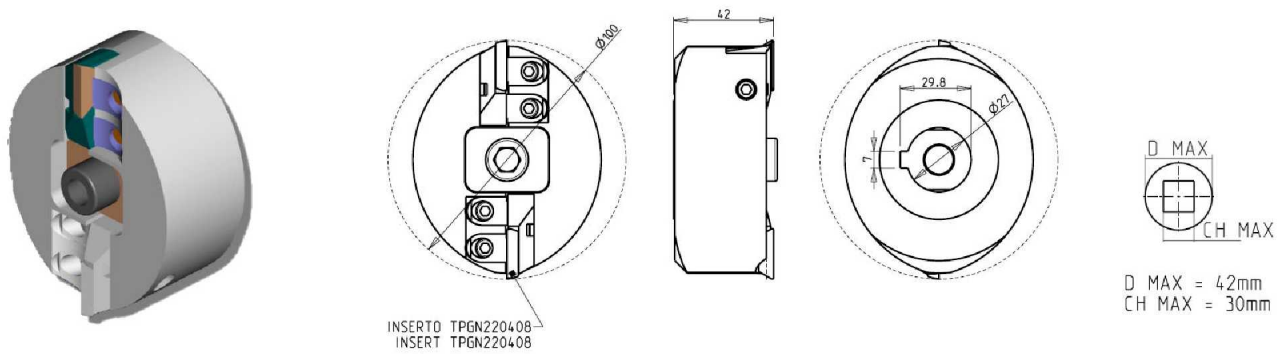

PartNumber	Description
P01Z20A100	2 Insert Polygon Making Mill Head (with Inserts)
TPGN220408	10 Inserts for Polygon Making Mill Heads

LB2000EX - LB3000EX

STATIC

RADIAL SINGLE TOOL STATIC HOLDER

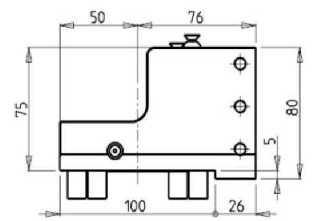
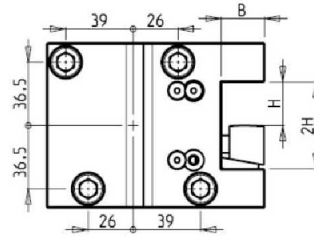
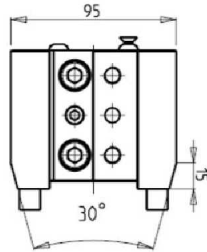
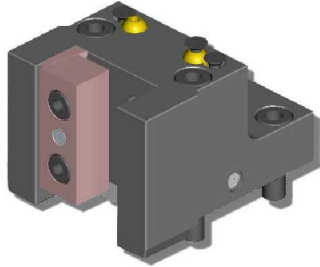

PartNumber	Description	Number of Tools	Reversible Main / Sub Spindle	Dimensions	B	H
OKU0091905	Radial Single Tool : 3/4"	1/2	X	Inch	3/4"	3/4"
OKU0092000	Radial Single Tool : 20mm	1/2	X	mm	20	20
OKU0092500	Radial Single Tool : 25mm	1/2	X	mm	25	25
OKU0092540	Radial Single Tool : 1"	1/2	X	Inch	1"	1"

RADIAL SINGLE SIDE DOUBLE TOOL STATIC HOLDER

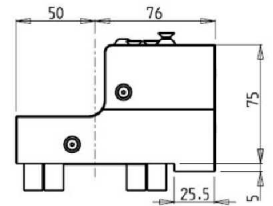
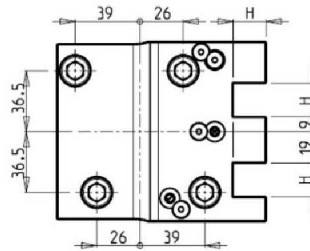
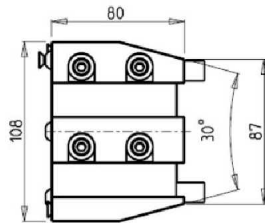
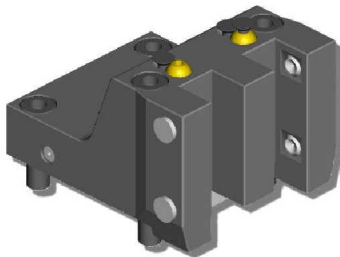

PartNumber	Description	Number of Tools	Reversible Main / Sub Spindle	Ext Coolant	H
OKU0182000	Radial Double Single-Side Tool 20mm	2	X	X	50

LB2000EX - LB3000EX

STATIC

RADIAL DOUBLE SIDE STATIC HOLDER

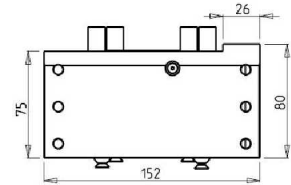
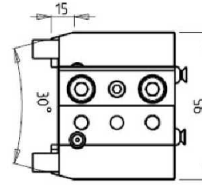
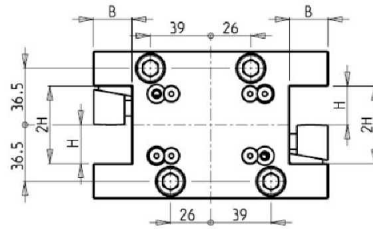
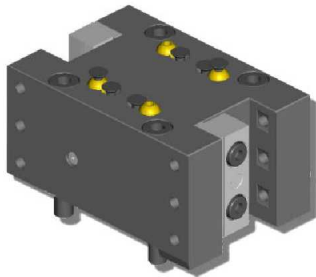

PartNumber	Description	Number of Tools	Reversible Main / Sub Spindle	Dimensions	B	H
OKU0151905	Radial Double Tool : 3/4"	2/4	X	mm	3/4"	3/4"
OKU0152540	Radial Double Tool : 1"	2/4	X	mm	1"	1"
OKU0152000	Radial Double Tool : 20mm	2/4	X	mm	20	20
OKU0152500	Radial Double Tool : 25mm	2/4	X	mm	25	25

RADIAL BLADE HOLDER

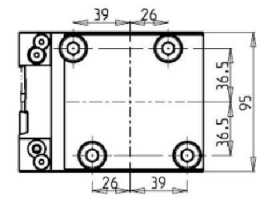
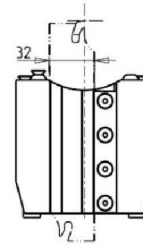
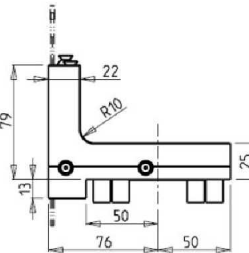
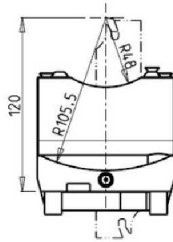
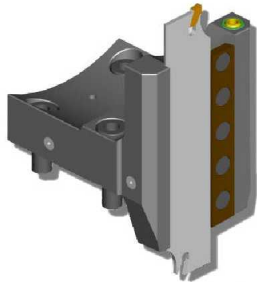

PartNumber	Description	Number of Tools	Reversible Main / Sub Spindle	Ext Coolant	NOTE:
OKU0230132	Radial Double Blade Holder	1	X	X	Provides close up cutting on the main/sub spindle.

LB2000EX - LB3000EX

STATIC

AXIAL SINGLE STATIC TOOL HOLDER

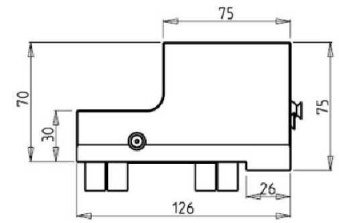
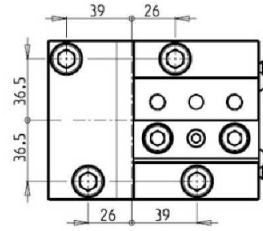
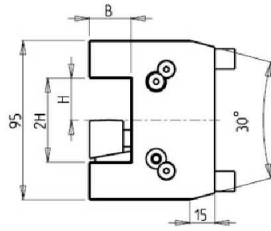
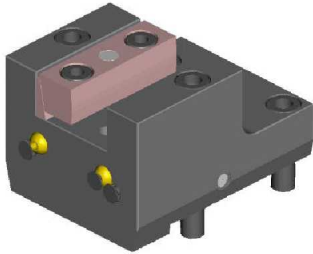

PartNumber	Description	Number of Tools	Reversible Main / Sub Spindle	Dimensions	B	H
OKU0161905	Axial Single Tool : 3/4"	1	X	Inch	3/4"	3/4"
OKU0162540	Axial Single Tool : 1"	1	X	Inch	1"	1"
OKU0162500	Axial Single Tool : 25mm	1	X	mm	25	25

AXIAL DOUBLE STATIC TOOL HOLDER

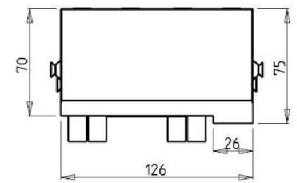
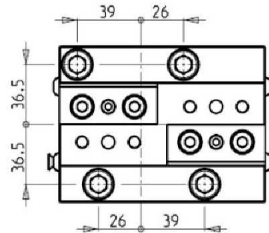
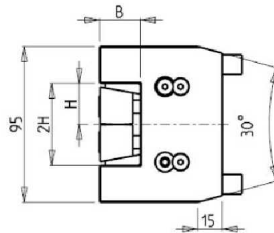
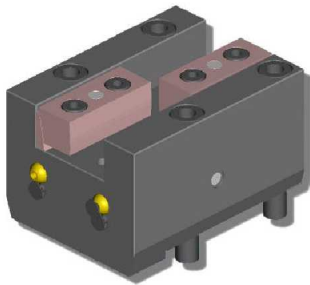

PartNumber	Description	Number of Tools	Reversible Main / Sub Spindle	Dimensions	B	H
OKU0171905	Axial Double Static Tool : 3/4"	2	X	Inch	3/4"	3/4"
OKU0172540	Axial Double Static Tool : 3/4"	2	X	Inch	1"	1"
OKU0172500	Axial Double Static Tool : 25mm	2	X		25	25

LB2000EX - LB3000EX

STATIC

AXIAL SINGLE BORING BAR HOLDER

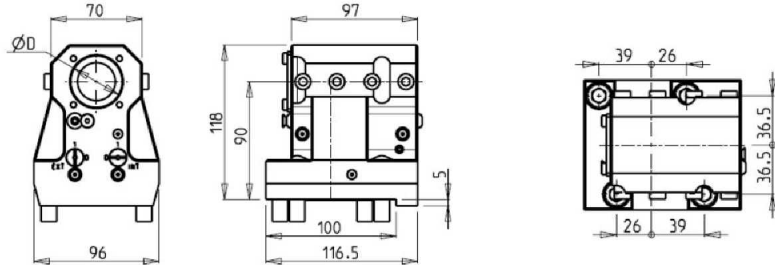
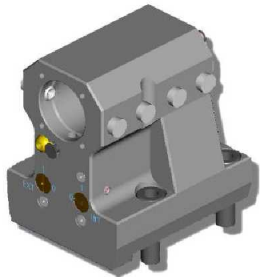

PartNumber	Description	Number of Tools	Coolant Thru	Ext Coolant	Dimensions	D
OKU0133175	Axial Single Boring Bar Holder : 1 1/4"	1	OPTION	X	Inch	1/14"
OKU0133810	Axial Single Boring Bar Holder : 1 1/2"	1	OPTION	X	Inch	1 1/2"
KIT1000020	32mm or 1-1/4" Plug to Make BBH Coolant Through					
KIT1000020	32mm or 1-1/4" Plug to Make BBH Coolant Through					
OKU0134000	Axial Single Boring Bar Holder : 40mm	1	OPTION	X	mm	40
OKU0133200	Axial Single Boring Bar Holder : 32mm	1	OPTION	X	mm	32
KIT1000019	40mm or 1-1/2" Plug to Make BBH Coolant Through					
KIT1000020	32mm or 1-1/4" Plug to Make BBH Coolant Through					

AXIAL DOUBLE BORING BAR HOLDER

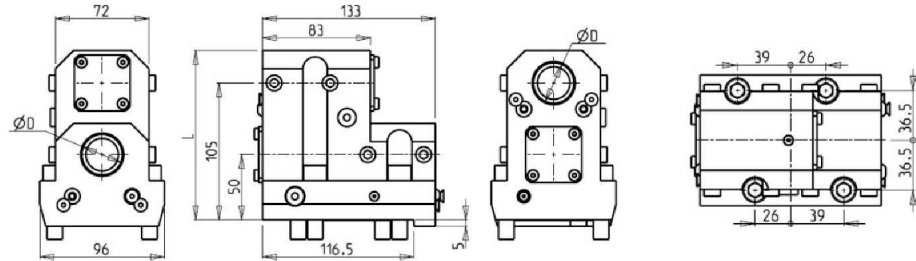
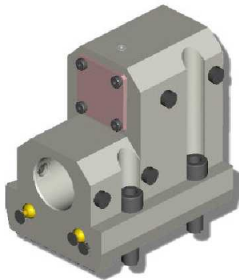

PartNumber	Description	Number of Tools	Coolant Thru	Ext Coolant	Dimensions	D	L
OKU0143175	Axial Double Boring Bar Holder : 1 1/4"	2	OPTION	X	Inch	1 1/4"	130
OKU0143810	Axial Double Boring Bar Holder : 1 1/2"	2	OPTION	X	Inch	1 1/2"	134
KIT1000019	40mm or 1-1/2" Plug to Make BBH Coolant Through						
KIT1000019	40mm or 1-1/2" Plug to Make BBH Coolant Through						
OKU0143200	Axial Double Boring Bar Holder : 32mm	2	OPTION	X	mm	32	130
OKU0144000	Axial Double Boring Bar Holder : 40mm	2	OPTION	X	mm	40	134
KIT1000019	40mm or 1-1/2" Plug to Make BBH Coolant Through						
KIT1000020	32mm or 1-1/4" Plug to Make BBH Coolant Through						

LB2000EX - LB3000EX

STATIC

AXIAL 4+4 POSITION BORING BAR HOLDER

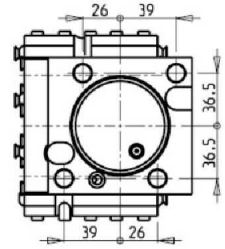
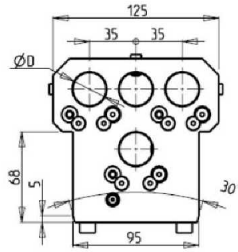
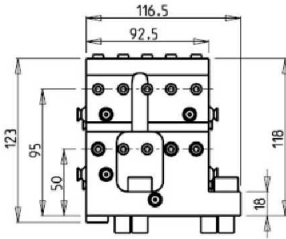
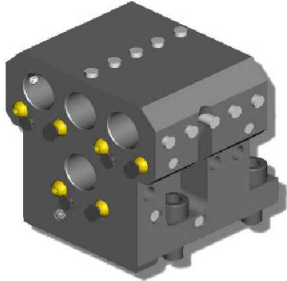

PartNumber	Description	Number of Tools	Ext Coolant	D
OKU0192540	Axial 4 + 4 Boring Bar Holder 25mm	4+4	X	1"
OKU0192500	Axial 4 + 4 Boring Bar Holder 25mm	4+4	X	25

Table of Contents

Part Number Index

K

KIT1000019	40mm or 1-1/2" Plug to Make BBH Coolant Through	7
KIT1000019	40mm or 1-1/2" Plug to Make BBH Coolant Through	7
KIT1000019	40mm or 1-1/2" Plug to Make BBH Coolant Through	7
KIT1000019	40mm or 1-1/2" Plug to Make BBH Coolant Through	7
KIT1000020	32mm or 1-1/4" Plug to Make BBH Coolant Through	7
KIT1000020	32mm or 1-1/4" Plug to Make BBH Coolant Through	7
KIT1000020	32mm or 1-1/4" Plug to Make BBH Coolant Through	7

O

OKU0060132	ER32A Standard	2
OKU0060232	ER32A Coolant Through *	2
OKU0060332	ER32 Standard	2
OKU0060340	ER40 Standard	2
OKU0060432	ER32 Coolant Through *	2
OKU0060440	ER40 Coolant Through *	2
OKU0060520	Weldon 20 Standard	2
OKU0060620	Weldon 20 Coolant Through *	2
OKU0061617	Milling Head D=16mm, L=17mm	2
OKU0062219	Milling Head D=22mm, L=19mm	2
OKU0062519	Milling Head D=1", L=19mm	2
OKU0062721	Milling Head D=27mm, L=21mm	2
OKU0070132	ER32A Standard	1
OKU0070232	ER32A Coolant Through *	1
OKU0070320	Weldon 20 Standard	1
OKU0070420	Weldon 20 Coolant Through *	1
OKU0071617	Milling Head D=16mm, L=17mm	1
OKU0072219	Milling Head D=22mm, L=19mm	1
OKU0072519	Milling Head D=1", L=19mm	1
OKU0072721	Milling Head D=27mm, L=21mm	1
OKU0091905	Radial Single Tool : 3/4"	4
OKU0092000	Radial Single Tool : 20mm	4
OKU0092500	Radial Single Tool : 25mm	4
OKU0092540	Radial Single Tool : 1"	4
OKU0133175	Axial Single Boring Bar Holder : 1 1/4"	7
OKU0133200	Axial Single Boring Bar Holder : 32mm	7
OKU0133810	Axial Single Boring Bar Holder : 1 1/2"	7
OKU0134000	Axial Single Boring Bar Holder : 40mm	7
OKU0143175	Axial Double Boring Bar Holder : 1 1/4"	7
OKU0143200	Axial Double Boring Bar Holder : 32mm	7
OKU0143810	Axial Double Boring Bar Holder : 1 1/2"	7
OKU0144000	Axial Double Boring Bar Holder : 40mm	7
OKU0151905	Radial Double Tool : 3/4"	5
OKU0152000	Radial Double Tool : 20mm	5
OKU0152500	Radial Double Tool : 25mm	5
OKU0152540	Radial Double Tool : 1"	5
OKU0161905	Axial Single Tool : 3/4"	6
OKU0162500	Axial Single Tool : 25mm	6
OKU0162540	Axial Single Tool : 1"	6
OKU0171905	Axial Double Static Tool : 3/4"	6
OKU0172500	Axial Double Static Tool : 25mm	6
OKU0172540	Axial Double Static Tool : 3/4"	6
OKU0182000	Radial Double Single-Side Tool 20mm	4
OKU0192500	Axial 4 + 4 Boring Bar Holder 25mm	8
OKU0192540	Axial 4 + 4 Boring Bar Holder 25mm	8
OKU0200232	Double Outlet ER32 / ER32 Opposite Face	2
OKU0230132	Radial Double Blade Holder	5

P

P01Z20A100	2 Insert Polygon Making Mill Head (with Inserts)	3
P01Z30A100	3 Insert Polygon Making Mill Head (with Inserts)	3

T

TPGN220408	10 Inserts for Polygon Making Mill Heads	3
TPGN220408	10 Inserts for Polygon Making Mill Heads	3