

DRIVEN TOOLING

For

Okuma Lathes

LB15, LB300, LT15, LR15, LU15M



10139 BERGIN RD.

HOWELL, MI 48843

PHONE : 877-91-TOOLS (810-632-4446)

FAX: 877-92-TOOLS (810-632-4467)

EMAIL: info@mdtooling.com

WEBSITE: www.mdtooling.com

June 2009

Live Tooling



Live Tool Technology

M. T. Marchetti, a major live tool manufacture in northern Italy, is a leader in live tool technology. The formula is simple. Use only the best angular contact high-speed bearings available. Add to this exacting tolerances for all ground shafts, gears and bearing pocket features. Next, develop a sealed system that **will not** allow any contamination from chips or coolant.

Top this all off with a superior design and you end up with a live tool that is more rigid, faster and will last longer. **We back this up with a 2-Year factory warranty.**

Our Live Tool Warranty

Our tooling will give years of service in the most demanding applications. The superior design and rugged construction has proven this over the last 12 years. The reliability of our tools allows us to provide a 2-year factory warranty.

MD TOOLING will repair any defective tool holders for a period of 2 years from the date of purchase.

Product Range

We have the largest range of live tooling available for most major machine tool manufactures.

Our available products include an extensive line of standard live tooling as well as specialty toolholders such as 0-90 and 0-180 adjustable angle tool holders, gear hobbers, and even worm gear generators. Our product range includes geared up holders to 60,000 RPM and are engineered for 1,000 PSI coolant through.

We are an industry leader in providing complete tooling solutions with hundreds of static tool options as well.

Technical Support

Here at MD Tooling we have a full technical support department with over 25 years of CNC experience.

Our highly qualified staff can help with part processing, tooling up a job from a blue print and even assist with part programming. Applications Engineers are always available by phone to answer any questions you may have about our tooling or any other CNC related issue.

Stock and Replenishment

MD Tooling maintains an extensive inventory of tooling in our warehouse in Michigan. Our current "fill" rate on orders is 93% from our stock in Michigan for same day shipping.

Should you require a non-stock item, our manufacturer, M.T. Marchetti also maintains a large inventory in Italy. Tooling can be obtained in as little as 3-5 business days.

Shipping

MD Tooling realizes that when you need tooling, often you can't wait until the next day. We process orders and ship from available stock right up until 5PM EST to make certain we get your tooling solutions to you as quickly as possible.

We regularly ship throughout the day via DHL, UPS, FedEx or any other carrier that a customer requests.



10139 Bergin Road

Howell, MI 48843

Phone: 810 632-4446

Fax: 810 632-4467

Email: info@mdtooling.com

Web: www.mdtooling.com

- 2-Year Warranty on all live tools.
- Quality tooling at highly competitive pricing.
- Extensive inventory. We currently ship over 93% of all orders same day.
- Fast, Friendly, Reliable Service!
- More specialty tool holders than any other manufacturer.
- Custom tool holders available.
- All available tooling may not be shown in this catalog. If you can't find the holder you're looking for, please contact this office for assistance.



Table of Contents

Categorized Listing

LB15/300, LT15, LR15, LU15M	1
DRIVEN	1
RADIAL DRIVEN TOOL 75mm INTERAXIS VDI40	1
RADIAL DRIVEN TOOL 90mm INTERAXIS VDI40	1
RADIAL DRIVEN TOOL 150mm INTERAXIS VDI40	2
RADIAL REAR SET DRIVEN TOOL VDI40	2
AXIAL DRIVEN TOOL VDI40	2
AXIAL DRIVEN TOOL 90mm INTERAXIS VDI40	3
AXIAL DRIVEN TOOL SUBSPINDLE SIDE 90mm INTERAXIS VDI40	3
AXIAL REDIRECTED DRIVEN TOOL VDI40	4
AXIAL GEARED DOWN REDIRECTED DRIVEN TOOL VDI40	4
AXIAL OPPOSITE FACE DRIVEN TOOL VDI40	5
0-90 ADJUSTABLE ANGLE DRIVEN TOOL VDI40	5
GEAR HOBBER VDI40	6

LB15/300, LT15, LR15, LU15M

DRIVEN

RADIAL DRIVEN TOOL 75mm INTERAXIS VDI40

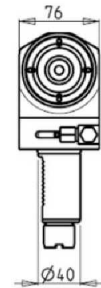
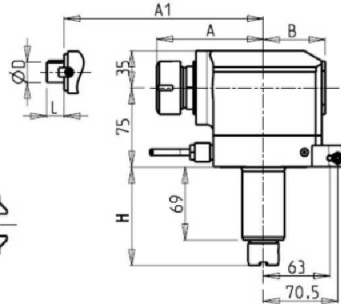
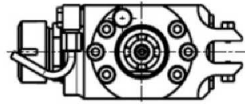
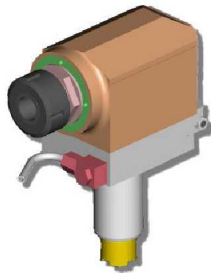

PartNumber	Description	Spindle	I	RPM	Coolant Thru	Ext Coolant	A	A1	B	H
OKU0040132	ER32 75mm Interaxis	ER32	1:1	4000		X	101.1		58.5	93
OKU0040232	ER32 75mm Interaxis Coolant Through *	ER32	1:1	4000	X	X	101.1		82	93
OKU0042219	Milling Head D=22mm, L=19mm	22x19	1:1	4000		X		78.5	58.5	93
OKU0042721	Milling Head D=27mm, L=21mm	27x21	1:1	4000		X		78.5	58.5	93

* Coolant Through tools are designed for 1000 psi.
They require 5 Micron Filtration and **CANNOT** be run dry.

RADIAL DRIVEN TOOL 90mm INTERAXIS VDI40

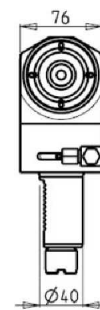
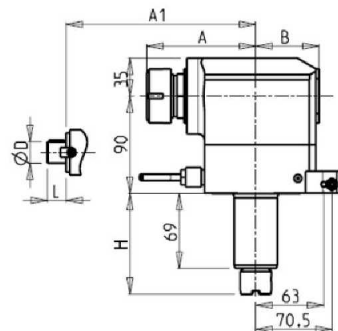
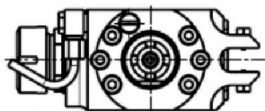
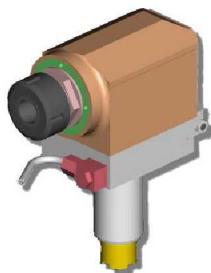

PartNumber	Description	Spindle	I	RPM	Coolant Thru	Ext Coolant	A	A1	B	H
OKU0050132	ER32 90mm Interaxis	ER32	1:1	4000		X	101.1		58.5	93
OKU0050232	ER32 90mm Interaxis Coolant Through *	ER32	1:1	4000	X	X	101.1		82	93
OKU0052219	Milling Head D=22mm, L=19mm	22x19	1:1	4000		X		78.5	58.5	93
OKU0052721	Milling Head D=27mm, L=21mm	27x21	1:1	4000		X		78.5	58.5	93

* Coolant Through tools are designed for 1000 psi.
They require 5 Micron Filtration and **CANNOT** be run dry.

LB15/300, LT15, LR15, LU15M

DRIVEN

RADIAL DRIVEN TOOL 150mm INTERAXIS VDI40

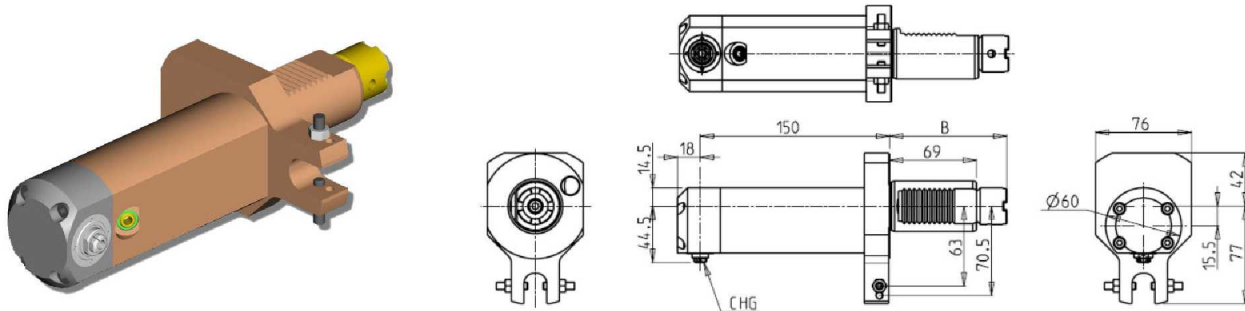

PartNumber	Description	Spindle	I	RPM	Ext Coolant	B
121OKU_R10_40B00	150mm Interaxis Interl Holes	CHG	1:1	4000	X	93

RADIAL REAR SET DRIVEN TOOL VDI40

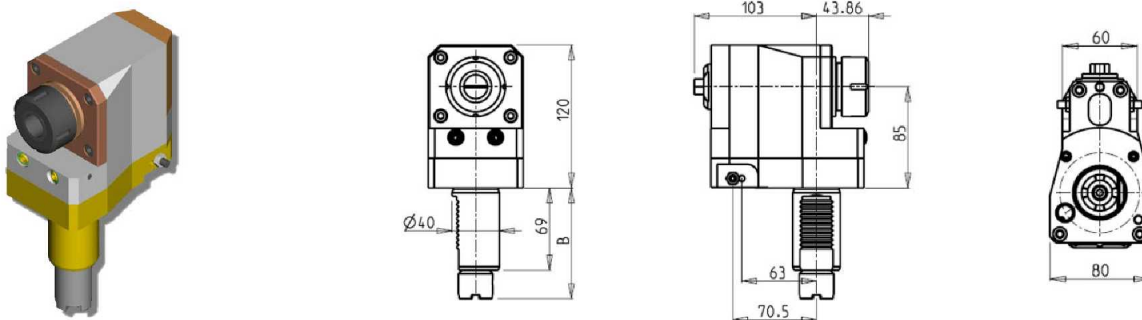

PartNumber	Description	Spindle	I	RPM	Ext Coolant	B
122OKU_R32_40B00	Rear-Set ER32 VDI40	ER32	1:1	4000	X	93

AXIAL DRIVEN TOOL VDI40

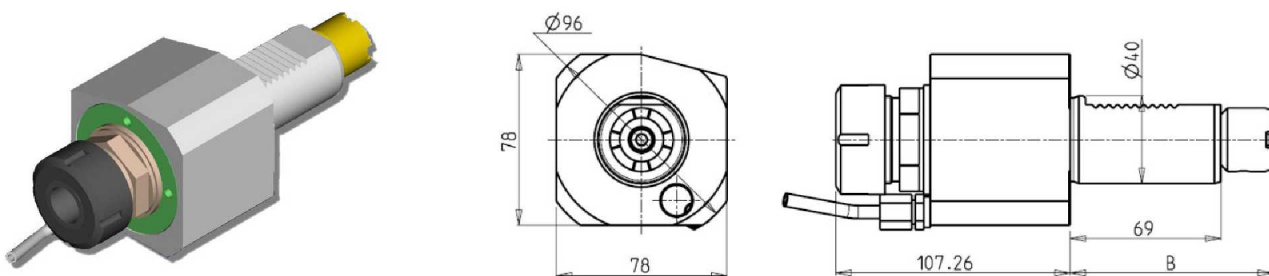

PartNumber	Description	Spindle	I	RPM	Ext Coolant	B
122OKU_A32_40B00	ER32 VDI40	ER32	1:1	4000	X	93
122OKU_A32_40B10	Weldon 8	Weldon 8	1:1	4000	X	93
122OKU_A32_40B12	Weldon 12	Weldon 12	1:1	4000	X	93
122OKU_A32_40B14	Weldon 16	Weldon 16	1:1	4000	X	93

LB15/300, LT15, LR15, LU15M

DRIVEN

AXIAL DRIVEN TOOL 90mm INTERAXIS VDI40

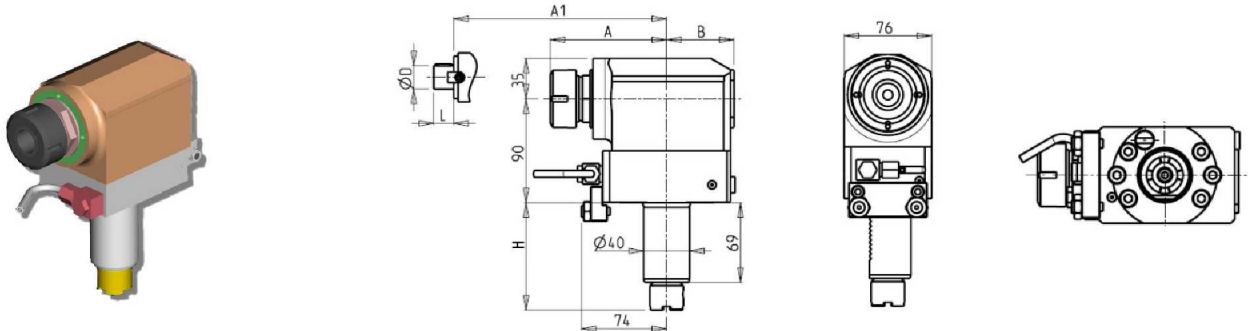

PartNumber	Description	Spindle	I	RPM	Coolant Thru	Ext Coolant	A	A1	B	H
OKU0020132	ER32 90mm Interaxis	ER32	1:1	4000		X	101.1		58.5	93
OKU0020232	ER32 90mm Interaxis Coolant Through*	ER32	1:1	4000	X	X	101.1		82	93
OKU0022219	Milling Head D=22mm,L=19mm 90mm Interaxis	22x19	1:1	4000		X		78.5	58.5	93
OKU0022721	Milling Head D=27mm,L=21mm 90mm Interaxis	27x21	1:1	4000		X		78.5	58.5	93

* Coolant Through tools are designed for 1000 psi.
They require 5 Micron Filtration and **CANNOT** be run dry.

AXIAL DRIVEN TOOL SUBSPINDLE SIDE 90mm INTERAXIS VDI40

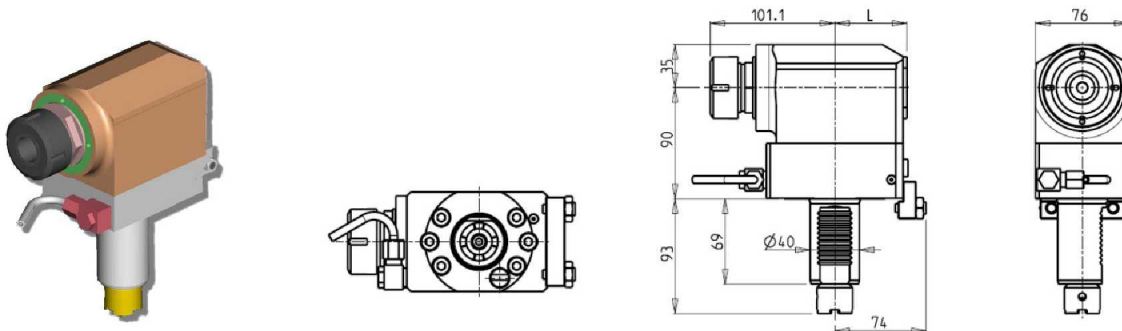

PartNumber	Description	Spindle	I	RPM	Coolant Thru	Ext Coolant	L
OKU0120132	ER32 Sub-Spindle VDI40 H=90mm	ER32	1:1	4000		X	58.5
OKU0120232	ER32 Sub-Spindle VDI40 H=90mm Coolant Thru*	ER32	1:1	4000	X	X	82

* Coolant Through tools are designed for 1000 psi.
They require 5 Micron Filtration and **CANNOT** be run dry.

LB15/300, LT15, LR15, LU15M

DRIVEN

AXIAL REDIRECTED DRIVEN TOOL VDI40

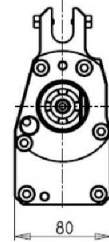
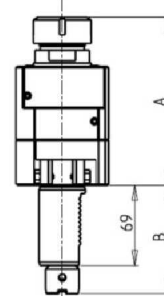
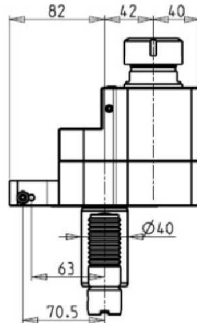

PartNumber	Description	Spindle	I	RPM	Coolant Thru	Ext Coolant	A	B
125OKU_A32_40B00	Redirected ER32 VDI40	ER32	1:1	4000		X	144.46	93
125OKU_A32_40B30	Redirected ER32 VDI40 Coolant Through *	ER32	1:1	4000	X	X	164.96	93

* Coolant Through tools are designed for 1000 psi.
They require 5 Micron Filtration and **CANNOT** be run dry.

AXIAL GEARED DOWN REDIRECTED DRIVEN TOOL VDI40

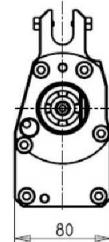
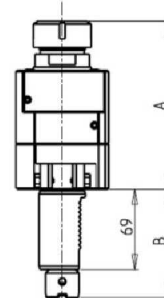
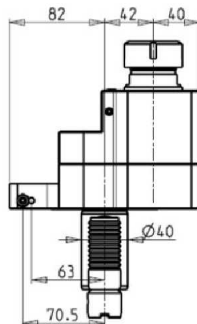
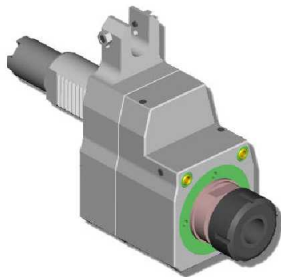

PartNumber	Description	Spindle	I	RPM	Coolant Thru	Ext Coolant	A	B
125OKU_A32_40B10	Geared Down 1:2 Redirected ER32 VDI 40	ER32	2:1	2000		X	144.46	93
125OKU_A32_40B20	Geared Down 1:2 Redirected ER32 VDI 40 Coolant Through *	ER32	2:1	2000	X	X	164.96	93

* Coolant Through tools are designed for 1000 psi.
They require 5 Micron Filtration and **CANNOT** be run dry.

LB15/300, LT15, LR15, LU15M

DRIVEN

AXIAL OPPOSITE FACE DRIVEN TOOL VDI40

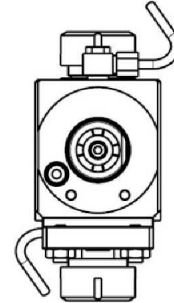
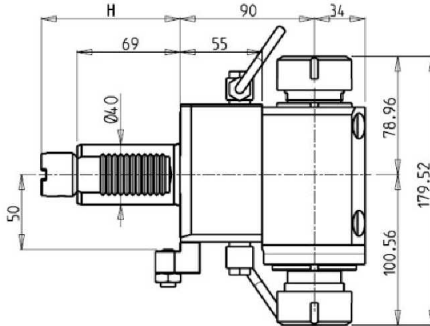
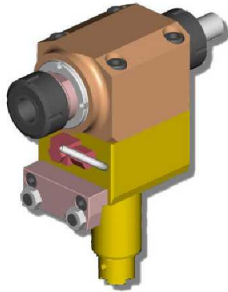

PartNumber	Description	Spindle	I	RPM	Ext Coolant	B
OKU0013232	Double Outlet ER32 / ER32 Opposite Face	ER32+ER32	1:1	4000	X	93

0-90 ADJUSTABLE ANGLE DRIVEN TOOL VDI40

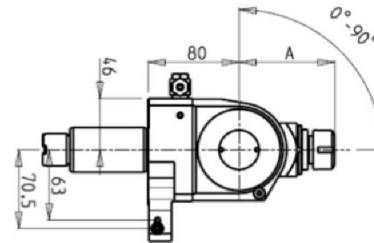
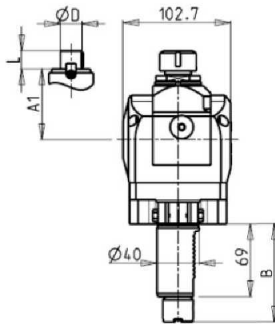
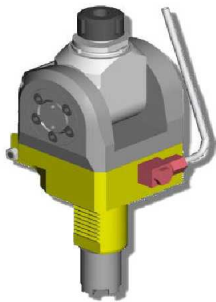

PartNumber	Description	Spindle	I	RPM	Ext Coolant	A	A1	B	D	L
0210020_OKU	Adjustable Angle (0-90) ER20 VDI40	ER20	1:1	4000	X	84.16		93		
0210025_OKU	Adjustable Angle (0-90) ER25 VDI40	ER25	1:1	4000	X	85.66		93		
0211617_OKU	Adjustable Angle (0-90) Mill Head 16x17 VDI40	16x17	1:1	4000	X		65	93	16	17
0212219_OKU	Adjustable Angle (0-90) Mill Head 22x19 VDI40	22x19	1:1	4000	X		66	93	22	19
0211905_OKU	Adjustable Angle (0-90) Mill Head 3/4x3/4 VDI40	3/4x3/4	1:1	4000	X		65	93	3/4	3/4

Note : Wrenches are provided with the purchase of Specialty Toolholders

LB15/300, LT15, LR15, LU15M

DRIVEN

GEAR HOBBER VDI40

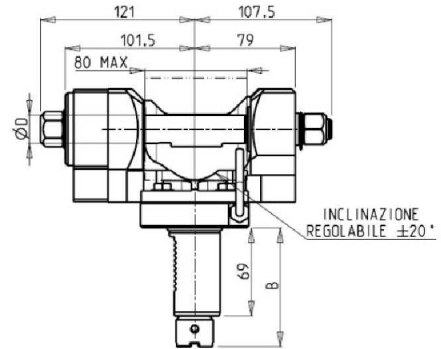
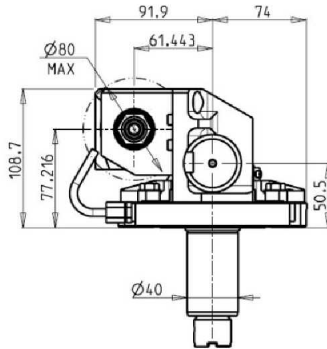
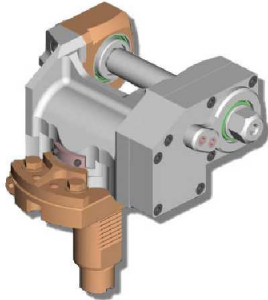

PartNumber	Description	Reversible Main / Sub Spindle	I	RPM	Ext Coolant	B	D mm	D Inch
126OKU_PCR_40B00	Gear Hob Tool 1:1 VDI40	X	1:1	4000	X	93	16-22-27-32	3/4 - 1 - 1 1/4
126OKU_PCR_40B10	Gear Hob : Geared Down 2:1 VDI40	X	2:1	2000	X	93	16-22-27-32	3/4 - 1 - 1 1/4

Note :

Wrenches are provided with the purchase of Specialty Toolholders

Table of Contents

Part Number Index

0

0210020_OKU	Adjustable Angle (0-90) ER20 VDI40	5
0210025_OKU	Adjustable Angle (0-90) ER25 VDI40	5
0211617_OKU	Adjustable Angle (0-90) Mill Head 16x17 VDI40	5
0211905_OKU	Adjustable Angle (0-90) Mill Head 3/4x3/4 VDI40	5
0212219_OKU	Adjustable Angle (0-90) Mill Head 22x19 VDI40	5

1

121OKU_R10_40B00	150mm Interaxis Interaxial Holes	2
121OKU_R32_40B00	Rear-Set ER32 VDI40	2
122OKU_A32_40B00	ER32 VDI40	2
122OKU_A32_40B10	Weldon 8	2
122OKU_A32_40B12	Weldon 12	2
122OKU_A32_40B14	Weldon 16	2
125OKU_A32_40B00	Redirected ER32 VDI40	4
125OKU_A32_40B10	Geared Down 1:2 Redirected ER32 VDI 40	4
125OKU_A32_40B20	Geared Down 1:2 Redirected ER32 VDI 40 Coolant Through *	4
125OKU_A32_40B30	Redirected ER32 VDI40 Coolant Through *	4
126OKU_PCR_40B00	Gear Hob Tool 1:1 VDI40	6
126OKU_PCR_40B10	Gear Hob : Geared Down 2:1 VDI40	6

O

OKU0013232	Double Outlet ER32 / ER32 Opposite Face	5
OKU0020132	ER32 90mm Interaxis	3
OKU0020232	ER32 90mm Interaxis Coolant Through*	3
OKU0022219	Milling Head D=22mm,L=19mm 90mm Interaxis	3
OKU0022721	Milling Head D=27mm,L=21mm 90mm Interaxis	3
OKU0040132	ER32 75mm Interaxis	1
OKU0040232	ER32 75mm Interaxis Coolant Through *	1
OKU0042219	Milling Head D=22mm, L=19mm	1
OKU0042721	Milling Head D=27mm, L=21mm	1
OKU0050132	ER32 90mm Interaxis	1
OKU0050232	ER32 90mm Interaxis Coolant Through *	1
OKU0052219	Milling Head D=22mm, L=19mm	1
OKU0052721	Milling Head D=27mm, L=21mm	1
OKU0120132	ER32 Sub-Spindle VDI40 H=90mm	3
OKU0120232	ER32 Sub-Spindle VDI40 H=90mm Coolant Thru*	3