

Mori Seiki ZT Series

DRIVEN AND STATIC TOOLING CATALOG



10139 BERGIN RD.
HOWELL, MI 48843
PHONE : 877-91-TOOLS (810-632-4446)
FAX: 877-92-TOOLS (810-632-4467)
EMAIL: info@mdtooling.com
WEBSITE: www.mdtooling.com

March 2009

Live Tooling

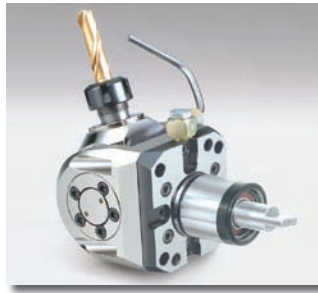

Live Tool Technology

M. T. Marchetti, a major live tool manufacture in northern Italy, is a leader in live tool technology. The formula is simple. Use only the best angular contact high-speed bearings available. Add to this exacting tolerances for all ground shafts, gears and bearing pocket features. Next, develop a sealed system that **will not** allow any contamination from chips or coolant.

Top this all off with a superior design and you end up with a live tool that is more rigid, faster and will last longer. **We back this up with a 2-Year factory warranty.**

Our Live Tool Warranty

Our tooling will give years of service in the most demanding applications. The superior design and rugged construction has proven this over the last 12 years. The reliability of our tools allows us to provide a 2-year factory warranty.

MD TOOLING will repair any defective tool holders for a period of 2 years from the date of purchase.

Product Range

We have the largest range of live tooling available for most major machine tool manufactures.

Our available products include an extensive line of standard live tooling as well as specialty toolholders such as 0-90 and 0-180 adjustable angle tool holders, gear hobbers, and even worm gear generators. Our product range includes geared up holders to 60,000 RPM and are engineered for 1,000 PSI coolant through.

We are an industry leader in providing complete tooling solutions with hundreds of static tool options as well.

Technical Support

Here at MD Tooling we have a full technical support department with over 25 years of CNC experience.

Our highly qualified staff can help with part processing, tooling up a job from a blue print and even assist with part programming. Applications Engineers are always available by phone to answer any questions you may have about our tooling or any other CNC related issue.

Stock and Replenishment

MD Tooling maintains an extensive inventory of tooling in our warehouse in Michigan. Our current "fill" rate on orders is 93% from our stock in Michigan for same day shipping.

Should you require a non-stock item, our manufacturer, M.T. Marchetti also maintains a large inventory in Italy. Tooling can be obtained in as little as 3-5 business days.

Shipping

MD Tooling realizes that when you need tooling, often you can't wait until the next day. We process orders and ship from available stock right up until 5PM EST to make certain we get your tooling solutions to you as quickly as possible.

We regularly ship throughout the day via DHL, UPS, FedEx or any other carrier that a customer requests.



10139 Bergin Road

Howell, MI 48843

Phone: 810 632-4446

Fax: 810 632-4467

Email: info@mdtooling.com

Web: www.mdtooling.com

Table of Contents

Categorized Listing

ZT 1000/1500	1
DRIVEN	1
RADIAL DRIVEN TOOL	1
AXIAL DRIVEN TOOL	1
OPPOSITE FACE AXIAL DRIVEN TOOL	2
POLYGON-MAKING MILL HEAD (3 INSERTS)	2
POLYGON-MAKING MILL HEAD (2 INSERTS)	3
AXIAL DRIVEN TOOL SUB SPINDLE SIDE	3
0-180 ADJUSTABLE ANGLE DRIVEN TOOL	4
STATIC	5
SINGLE RADIAL STATIC TOOL	5
DOUBLE RADIAL STATIC TOOL	5
SINGLE RADIAL STATIC TOOL SUB SPINDLE SIDE	5
RADIAL DOUBLE BLADE HOLDER	6
SINGLE AXIAL STATIC TOOL	6
SINGLE AXIAL BORING BAR HOLDER 65mm INTERAXIS	6
REAR SET BORING BAR HOLDER ON MAIN SPINDLE SIDE, EXTENDED ONTS	6
DOUBLE AXIAL BORING BAR HOLDER	7
ZT 2500 & MT 2000/2500	8
DRIVEN	8
RADIAL DRIVEN TOOL	8
AXIAL DRIVEN TOOL - MAIN SPINDLE	8
AXIAL DRIVEN TOOL - SUB SPINDLE SIDE	9
OPPOSITE FACE AXIAL DRIVEN TOOL	9

ZT 1000/1500

DRIVEN

RADIAL DRIVEN TOOL

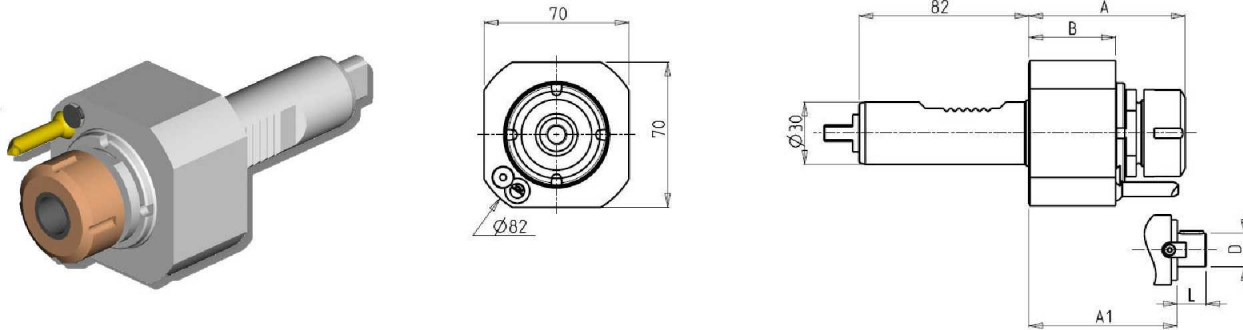

PartNumber	Description	Mori Ref	Spindle	I	RPM	Cool Thru	Ext Cool	A	A1	B	D	L
M0150125	Radial ER25 Standard	T32405	ER25	1:1	6000		X	75.66		42		
M0151125	Radial ER25 Coolant Through*		ER25	1:1	6000	X		95.66		62		
M0151617	Radial D=16mm, L=17mm		16x17	1:1	6000		X		61	42	16	17
M0152219	Radial D=22mm, L=19mm		22x19	1:1	6000		X		59	42	22	19

* Coolant Through tools are designed for 1000 psi.
They require 5 Micron Filtration and **CANNOT** be run dry.

AXIAL DRIVEN TOOL

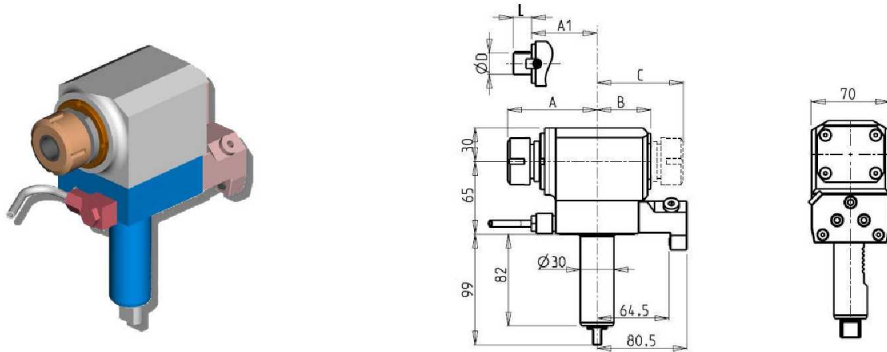

PartNumber	Description	Mori Ref	Spindle	I	RPM	Cool Thru	Ext Cool	A	A1	B	D	L
M0121425	ER25 Standard	T32406	ER25	1:1	6000		X	80.16		48		
M0121525	ER25 Coolant Through*	T32415	ER25	1:1	6000	X	X	80.16		71.5		
M0121617	Milling Head D=16mm, L=17mm		16x17	1:1	6000		X		63	48	16	17
M0122219	Milling Head D=22mm, L=19mm		22x19	1:1	6000		X		63	48	22	19
M0122721	Polygon / Milling Head D=27mm, L=21mm		27x21	1:1	6000		X		65.5	48	27	21

* Coolant Through tools are designed for 1000 psi.
They require 5 Micron Filtration and **CANNOT** be run dry.

ZT 1000/1500

DRIVEN

OPPOSITE FACE AXIAL DRIVEN TOOL

Image
Currently
Unavailable

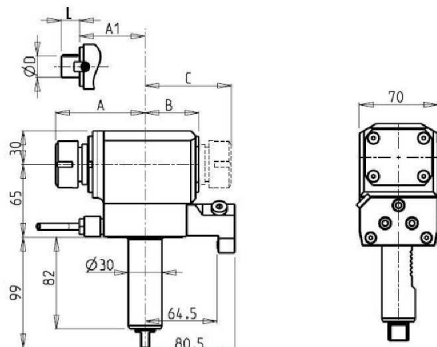

PartNumber	Description	Mori Ref	Spindle	I	RPM	Ext Coolant	A	C
M0132525	Double Outlet ER25/ER25	T32408	ER25 + ER25	1:1	6000	X	80.16	73.66

POLYGON-MAKING MILL HEAD (3 INSERTS)

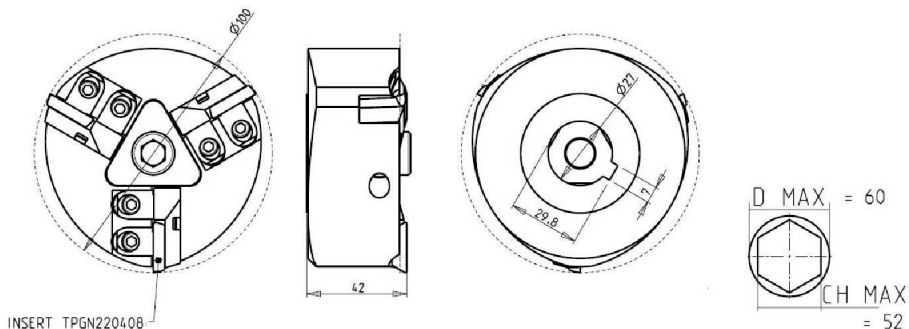
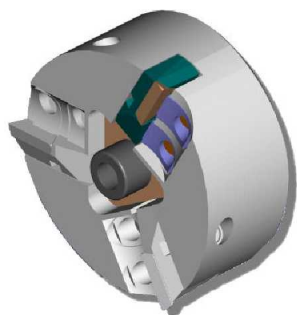

PartNumber	Description
P01Z30A100	External Polygon-making Head with 3 inserts
TPGN220408	Insert for Polygon-making Head (each)

Note: These Polygon Making Mill Heads are for use with our Axial Tool #M0122721

ZT 1000/1500

DRIVEN

POLYGON-MAKING MILL HEAD (2 INSERTS)

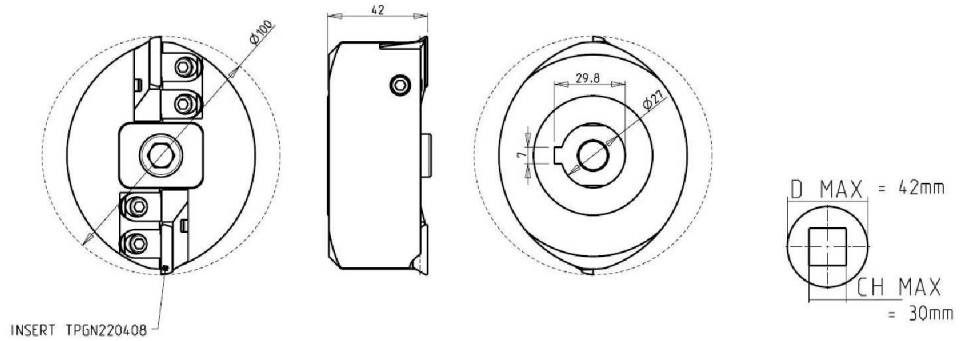
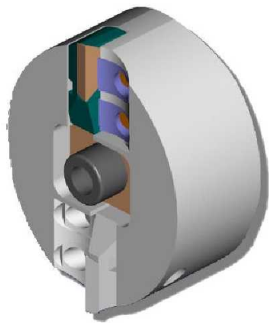

PartNumber	Description
P01Z20A100	External Polygon-making Head with 2 inserts
TPGN220408	Insert for Polygon-making Head (each)

Note: These Polygon Making Mill Heads are for use with our Axial Tool #M0122721

AXIAL DRIVEN TOOL SUB SPINDLE SIDE

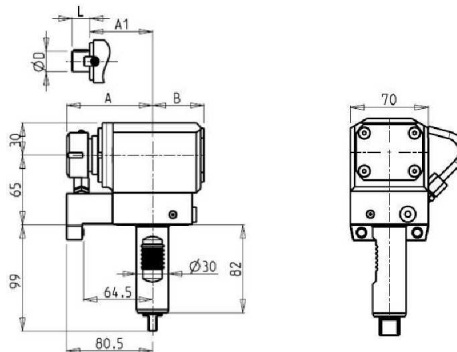
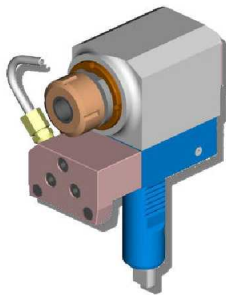

PartNumber	Description	Mori Ref	Spindle	I	RPM	Cool Thru	Ext Cool	A	A1	B	D	L
M0141425	Driven Tool for Sub-Spindle ER25	T32407	ER25	1:1	6000		X	80.16		48		
M0141525	Sub Spindle Milling Head ER25 Coolant Through *		ER25	1:1	6000	X	X	80.16		71.5		
M0141617	Sub Spindle Milling Head D=16mm, L=17mm		16x17	1:1	6000		X		63	48	16	17
M0142219	Sub Spindle Milling Head D=22mm, L=19mm		22x19	1:1	6000		X		63	48	22	19
M0142721	Sub Spindle Milling Head D=27mm, L=21mm		27x21	1:1	6000		X		65.5	48	27	21

* Coolant Through tools are designed for 1000 psi. They require 5 Micron Filtration and **CANNOT** be run dry.

ZT 1000/1500

DRIVEN

0-180 ADJUSTABLE ANGLE DRIVEN TOOL

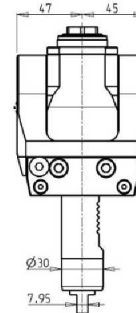
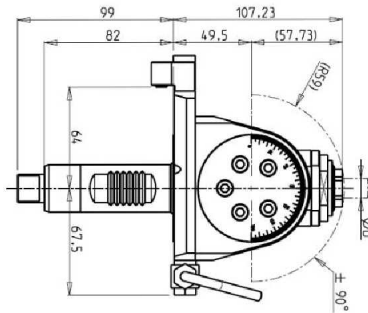
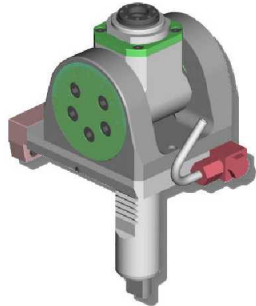

PartNumber	Description	Spindle	I	RPM	Ext Coolant	D Max	D Min
M0180020	Adjustable Angle (0-180) ER20	ER20A	1:1	6000	X	13	1

Note : Wrenches are provided with the purchase of Specialty Toolholders

ZT 1000/1500

STATIC

SINGLE RADIAL STATIC TOOL

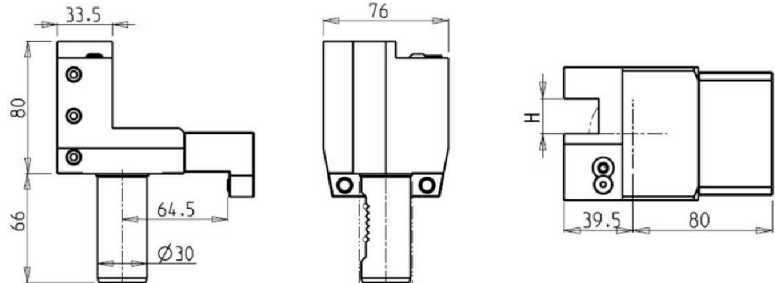
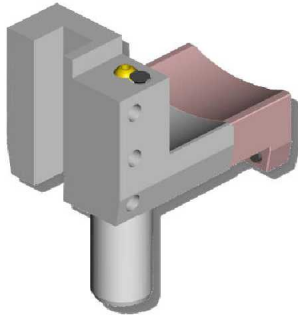

PartNumber	Description	Mori Ref	Num of Tools	Dimensions	H
M0191905	Radial Static Tool 3/4"		1	Inch	3/4"
M0192000	Radial Static Tool 20mm	T00336	1	mm	20

DOUBLE RADIAL STATIC TOOL

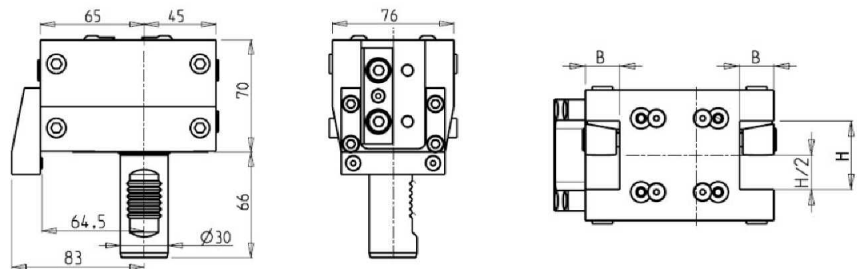
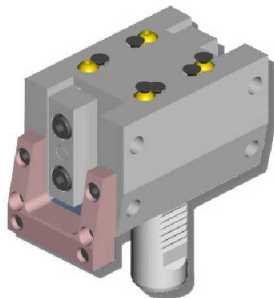

PartNumber	Description	Mori Ref	Num of Tools	Dimensions	B	H
M0171905	Double Tool Holder : 3/4" x 1 1/2"		2 / 4	Inch	3/4"	1 1/2"
M0172000	Double Tool Holder : 20mm x 40mm	T00331	2 / 4	mm	20	40

SINGLE RADIAL STATIC TOOL SUB SPINDLE SIDE

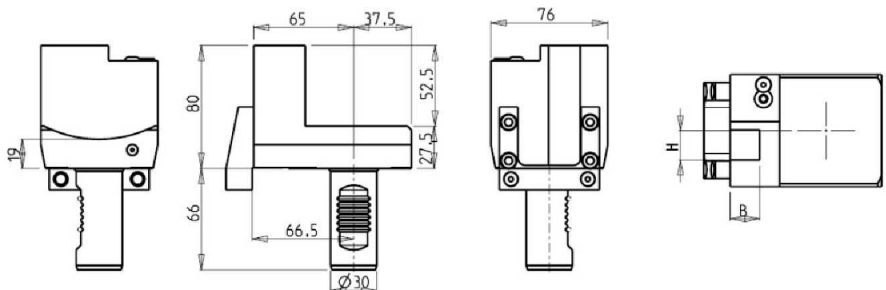
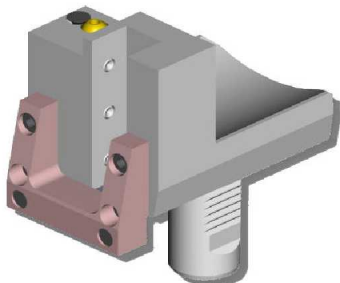

PartNumber	Description	Num of Tools	Dimensions	B	H Max
M0190119	Radial Static Tool SubSpindle 3/4"	1	Inch	3/4"	3/4"
M0190120	Radial Static Tool SubSpindle 20mm	1	mm	20	20

ZT 1000/1500

STATIC

RADIAL DOUBLE BLADE HOLDER

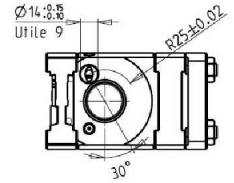
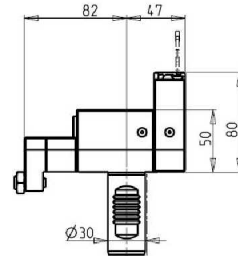
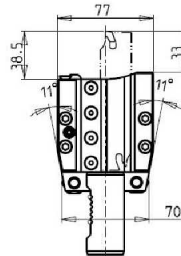
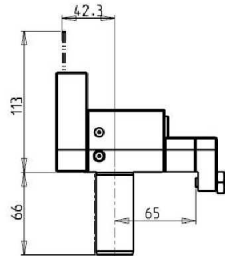
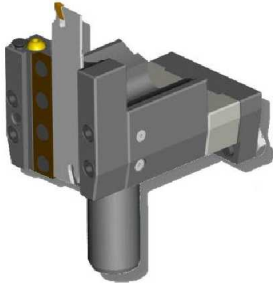

PartNumber	Description	Num of Tools
MZT0030126	Double Blade Holder	1
BLADEKIT	Blade Kit: 1 Blade, 10 Inserts for MZT0030126	

SINGLE AXIAL STATIC TOOL

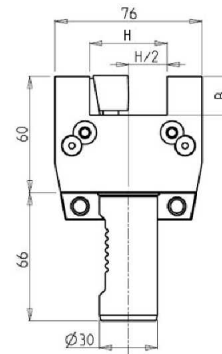
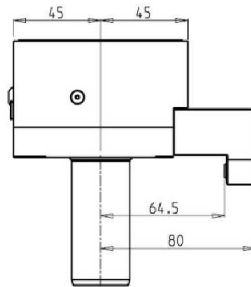
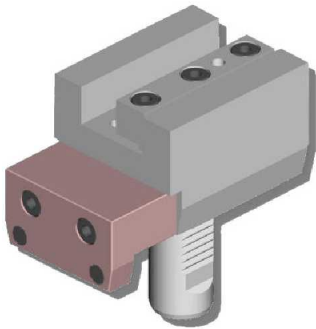

PartNumber	Description	Mori Ref	Num of Tools	Dimensions	B	H
M0201905	Axial Static Tool: 3/4" x 1 1/2"		1	Inch	3/4"	1 1/2"
M0202000	Axial Static Tool: 20mm x 40mm	T03113	1	mm	20	40

SINGLE AXIAL BORING BAR HOLDER 65mm INTERAXIS

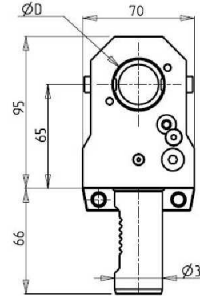
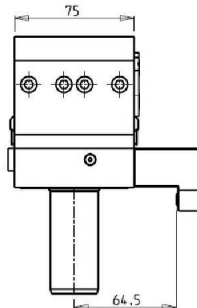
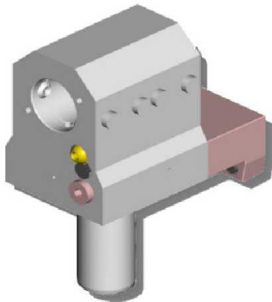

PartNumber	Description	Mori Ref	Num of Tools	Coolant Thru	Ext Coolant	Dimensions	D
M0163175	Boring Bar Holder : 1-1/4"		1	OPTION	X	Inch	1 1/4"
M0163200	Boring Bar Holder 32mm	T15003	1	OPTION	X	mm	32
M0164000	Boring Bar Holder 40mm		1	OPTION	X	mm	40
KIT1000001	32mm or 1-1/4" Plug to make BBH Coolant Through						
KIT1000003	40mm Plug to make BBH Coolant Through						

ZT 1000/1500

STATIC

REAR SET BORING BAR HOLDER ON MAIN SPINDLE SIDE, EXTENDED ON SUBSPINDLE SIDE

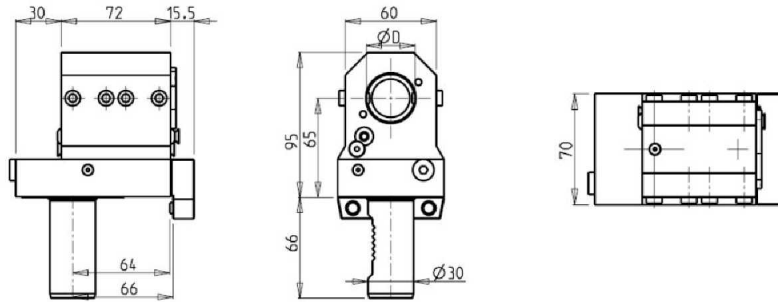
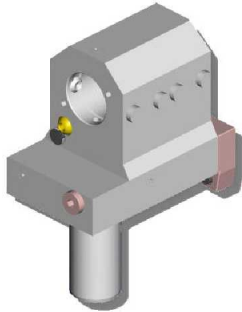

PartNumber	Description	Num of Tools	Coolant Thru	Ext Coolant	Dimensions	D
MZT0023175	Boring Bar Holder 1 1/4"	1	OPTION	X	Inch	1 1/4"
MZT0023200	Boring Bar Holder 32mm	1	OPTION	X	mm	32
KIT1000001	32mm or 1-1/4" Plug to make BBH Coolant Through					

DOUBLE AXIAL BORING BAR HOLDER

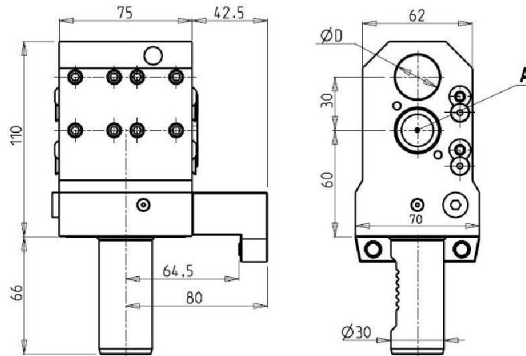
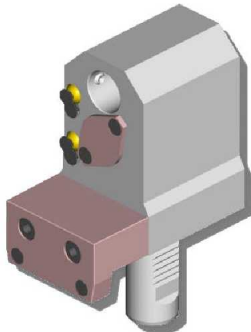

PartNumber	Description	Num of Tools	Coolant Thru	Ext Coolant	Dimensions	D
M0212540	Double Boring Bar Holder : 1.00"	2	Option A Only	X	Inch	1"
M0212500	Double Boring Bar Holder : 25mm	2	Option A Only	X	mm	25
KIT1000006	25mm or 1" Plug to make BBH Coolant Through					

ZT 2500 & MT 2000/2500

DRIVEN

RADIAL DRIVEN TOOL

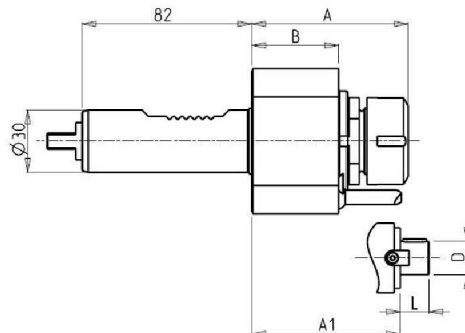
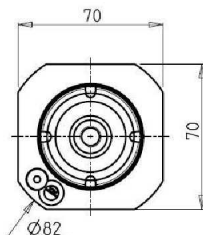
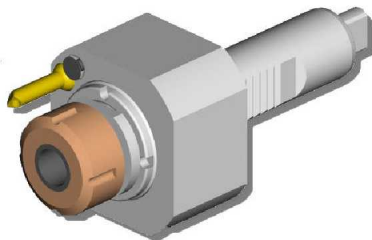

PartNumber	Description	Spindle	I	RPM	Coolant Thru	Ext Coolant	A	B
MMT0020140	ER40 Standard	ER40	1:1	6000		X	99.66	59
MMT0020240	ER40 Coolant Through*	ER40	1:1	6000	X	X	112.66	72

* Coolant Through tools are designed for 1000 psi.
They require 5 Micron Filtration and **CANNOT** be run dry.

AXIAL DRIVEN TOOL - MAIN SPINDLE

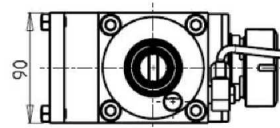
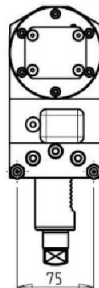
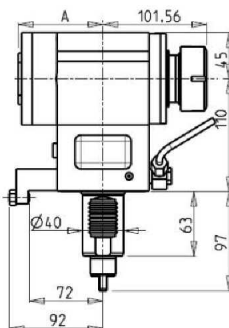
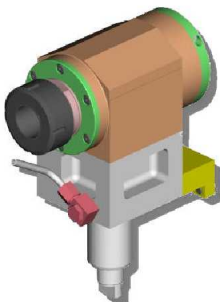

PartNumber	Description	Spindle	I	RPM	Coolant Thru	Ext Coolant	A
MMT0010140	ER40 Standard Main Spindle	ER40	1:1	6000		X	82.95
MMT0010340	ER40 Coolant Through* Main Spindle	ER40	1:1	6000	X	X	106.45

* Coolant Through tools are designed for 1000 psi.
They require 5 Micron Filtration and **CANNOT** be run dry.

ZT 2500 & MT 2000/2500

DRIVEN

AXIAL DRIVEN TOOL - SUB SPINDLE SIDE

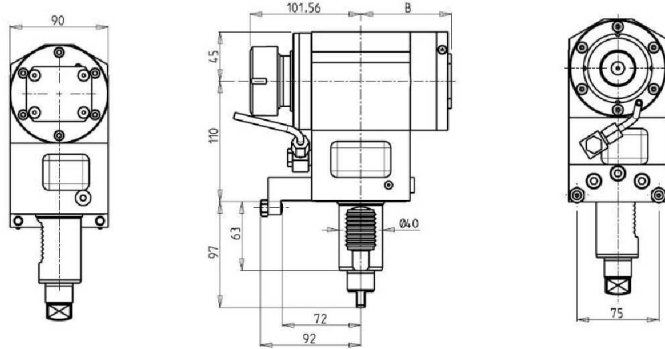
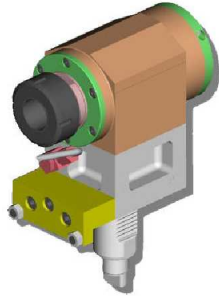

PartNumber	Description	Spindle	I	RPM	Coolant Thru	Ext Coolant	A
MMT0011040	ER40 Standard Sub Spindle	ER40	1:1	6000		X	82.95
MMT0011140	ER40 Coolant Through* Sub Spindle	ER40	1:1	6000	X	X	106.45

* Coolant Through tools are designed for 1000 psi.
They require 5 Micron Filtration and **CANNOT** be run dry.

OPPOSITE FACE AXIAL DRIVEN TOOL

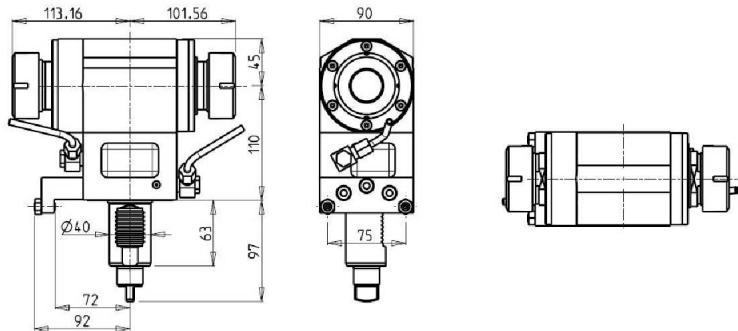
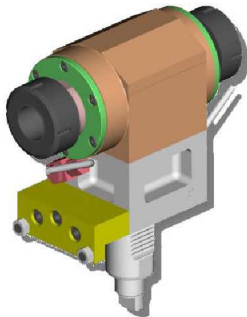

PartNumber	Description	Spindle	I	RPM	Ext Coolant
MMT0010240	ER40+ER40 Main/Sub Spindle	ER40 + ER40	1:1	6000	X

Table of Contents

Part Number Index

B

BLADEKIT	Blade Kit: 1 Blade, 10 Inserts for MZT0030126	6
----------	---	---

K

KIT1000001	32mm or 1-1/4" Plug to make BBH Coolant Through	6
KIT1000001	32mm or 1-1/4" Plug to make BBH Coolant Through	7
KIT1000003	40mm Plug to make BBH Coolant Through	6
KIT1000006	25mm or 1" Plug to make BBH Coolant Through	7

M

M0121425	ER25 Standard	1
M0121525	ER25 Coolant Through*	1
M0121617	Milling Head D=16mm, L=17mm	1
M0122219	Milling Head D=22mm, L=19mm	1
M0122721	Polygon / Milling Head D=27mm, L=21mm	1
M0132525	Double Outlet ER25/ER25	2
M0141425	Driven Tool for Sub-Spindle ER25	3
M0141525	Sub Spindle Milling Head ER25 Coolant Through *	3
M0141617	Sub Spindle Milling Head D=16mm, L=17mm	3
M0142219	Sub Spindle Milling Head D=22mm, L=19mm	3
M0142721	Sub Spindle Milling Head D=27mm, L=21mm	3
M0150125	Radial ER25 Standard	1
M0151125	Radial ER25 Coolant Through*	1
M0151617	Radial D=16mm, L=17mm	1
M0152219	Radial D=22mm, L=19mm	1
M0163175	Boring Bar Holder : 1-1/4"	6
M0163200	Boring Bar Holder 32mm	6
M0164000	Boring Bar Holder 40mm	6
M0171905	Double Tool Holder : 3/4" x 1 1/2"	5
M0172000	Double Tool Holder : 20mm x 40mm	5
M0180020	Adjustable Angle (0-180) ER20	4
M0190119	Radial Static Tool SubSpindle 3/4"	5
M0190120	Radial Static Tool SubSpindle 20mm	5
M0191905	Radial Static Tool 3/4"	5
M0192000	Radial Static Tool 20mm	5
M0201905	Axial Static Tool: 3/4" x 1 1/2"	6
M0202000	Axial Static Tool: 20mm x 40mm	6
M0212500	Double Boring Bar Holder : 25mm	7
M0212540	Double Boring Bar Holder : 1.00"	7
MMT0010140	ER40 Standard Main Spindle	8
MMT0010240	ER40+ER40 Main/Sub Spindle	9
MMT0010340	ER40 Coolant Through* Main Spindle	8
MMT0011040	ER40 Standard Sub Spindle	9
MMT0011140	ER40 Coolant Through* Sub Spindle	9
MMT0020140	ER40 Standard	8
MMT0020240	ER40 Coolant Through*	8
MZT0023175	Boring Bar Holder 1 1/4"	7
MZT0023200	Boring Bar Holder 32mm	7
MZT0030126	Double Blade Holder	6

P

P01Z20A100	External Polygon-making Head with 2 inserts	3
P01Z30A100	External Polygon-making Head with 3 inserts	2

T

TPGN220408	Insert for Polygon-making Head (each)	3
TPGN220408	Insert for Polygon-making Head (each)	2