

DRIVEN TOOLING
For
Mazak Lathes
SQT 200-250
12 Station Lathes



10139 BERGIN RD.
HOWELL, MI 48843
PHONE : 877-91-TOOLS (810-632-4446)
FAX: 877-92-TOOLS (810-632-4467)
EMAIL: info@mdtooling.com
WEBSITE: www.mdtooling.com

June 2009

Live Tooling



Live Tool Technology

M. T. Marchetti, a major live tool manufacture in northern Italy, is a leader in live tool technology. The formula is simple. Use only the best angular contact high-speed bearings available. Add to this exacting tolerances for all ground shafts, gears and bearing pocket features. Next, develop a sealed system that **will not** allow any contamination from chips or coolant.

Top this all off with a superior design and you end up with a live tool that is more rigid, faster and will last longer. **We back this up with a 2-Year factory warranty.**

Our Live Tool Warranty

Our tooling will give years of service in the most demanding applications. The superior design and rugged construction has proven this over the last 12 years. The reliability of our tools allows us to provide a 2-year factory warranty.

MD TOOLING will repair any defective tool holders for a period of 2 years from the date of purchase.

Product Range

We have the largest range of live tooling available for most major machine tool manufactures.

Our available products include an extensive line of standard live tooling as well as specialty toolholders such as 0-90 and 0-180 adjustable angle tool holders, gear hobbers, and even worm gear generators. Our product range includes geared up holders to 60,000 RPM and are engineered for 1,000 PSI coolant through.

We are an industry leader in providing complete tooling solutions with hundreds of static tool options as well.

Technical Support

Here at MD Tooling we have a full technical support department with over 25 years of CNC experience.

Our highly qualified staff can help with part processing, tooling up a job from a blue print and even assist with part programming. Applications Engineers are always available by phone to answer any questions you may have about our tooling or any other CNC related issue.

Stock and Replenishment

MD Tooling maintains an extensive inventory of tooling in our warehouse in Michigan. Our current "fill" rate on orders is 93% from our stock in Michigan for same day shipping.

Should you require a non-stock item, our manufacturer, M.T. Marchetti also maintains a large inventory in Italy. Tooling can be obtained in as little as 3-5 business days.

Shipping

MD Tooling realizes that when you need tooling, often you can't wait until the next day. We process orders and ship from available stock right up until 5PM EST to make certain we get your tooling solutions to you as quickly as possible.

We regularly ship throughout the day via DHL, UPS, FedEx or any other carrier that a customer requests.



10139 Bergin Road

Howell, MI 48843

Phone: 810 632-4446

Fax: 810 632-4467

Email: info@mdtooling.com

Web: www.mdtooling.com

- 2-Year Warranty on all live tools.
- Quality tooling at highly competitive pricing.
- Extensive inventory. We currently ship over 93% of all orders same day.
- Fast, Friendly, Reliable Service!
- More specialty tool holders than any other manufacturer.
- Custom tool holders available.
- All available tooling may not be shown in this catalog. If you can't find the holder you're looking for, please contact this office for assistance.



Table of Contents

Categorized Listing

SQT 200-250 12 Station	1
DRIVEN	1
RADIAL DRIVEN TOOL	1
RADIAL RE-DIRECTED DRIVEN TOOL 50mm	1
GEARED UP RADIAL REDIRECTED TOOL 50mm	2
GEARED DOWN RADIAL REDIRECTED TOOL 50mm	2
AXIAL DRIVEN TOOL	3
AXIAL DRIVEN OPPOSITE FACE TOOL	3
0-90 ADJUSTABLE ANGLE DRIVEN TOOL	4
0-180 ADJUSTABLE ANGLE DRIVEN TOOL	4
STATIC	5
RADIAL SINGLE TOOL STATIC HOLDER	5
RADIAL SINGLE TOOL DOUBLE SIDED STATIC HOLDER	5
RADIAL DOUBLE BLADE HOLDER	5
AXIAL SINGLE TOOL STATIC HOLDER	6
AXIAL SINGLE BORING BAR HOLDER 130mm INTERAXIS	6
AXIAL SINGLE BORING BAR HOLDER 140mm INTERAXIS	7

SQT 200-250 12 Station

DRIVEN

RADIAL DRIVEN TOOL

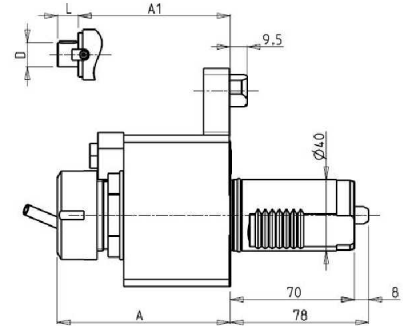
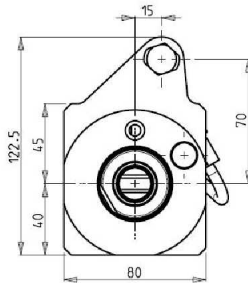
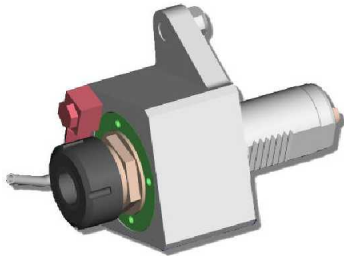

PartNumber	Description	Spindle	I	RPM	Coolant Thru	Ext Coolant	A	A1	D	L
MZK0090232	ER32 Standard	ER32	1:1	4500		X	97.46			
MZK0091232	ER32 Coolant Through *	ER32	1:1	4500	X	X	110.46			
MZK0090225	ER25A Standard	ER25A	1:1	4500		X	83.33			
MZK0092219	Milling Head D=22mm, L=19mm	22x19	1:1	4500		X		98.8	22	19

* Coolant Through tools are designed for 1000 psi.
They require 5 Micron Filtration and **CANNOT** be run dry.

RADIAL RE-DIRECTED DRIVEN TOOL 50mm

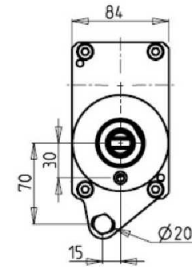
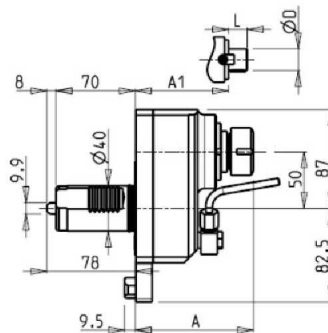
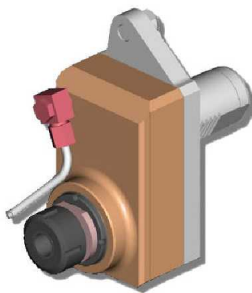

PartNumber	Description	Spindle	I	RPM	Ext Coolant	A	A1	D	L
MZK0010025	ER25 Redirected	ER25	1:1	4500	X	104.5			
MZK0010032	ER32 Redirected	ER32	1:1	4500	X	118.1			
MZK0010017	Milling Head D=16mm, L=17mm Redirected	16x17	1:1	4500	X		86	16	17
MZK0010019	Milling Head D=22mm, L=19mm Redirected	22x19	1:1	4500	X		88	22	19
MZK0010027	Milling Head D=27mm, L=21mm Redirected	27x21	1:1	4500	X		90	27	21

SQT 200-250 12 Station

DRIVEN

GEARED UP RADIAL REDIRECTED TOOL 50mm

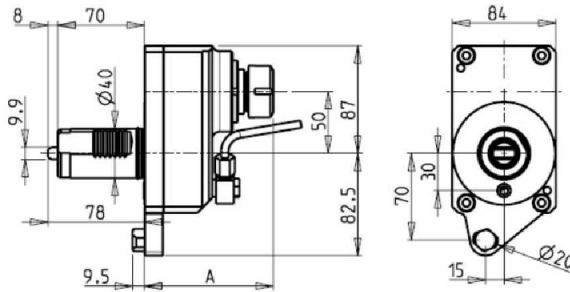
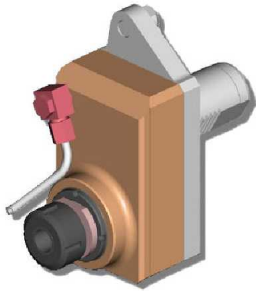

PartNumber	Description	Spindle	I	RPM	Ext Coolant	A
MZK0012125	Geared Up 2:1 ER25 Redirected	ER25	1:2	9000	X	118.1

GEARED DOWN RADIAL REDIRECTED TOOL 50mm

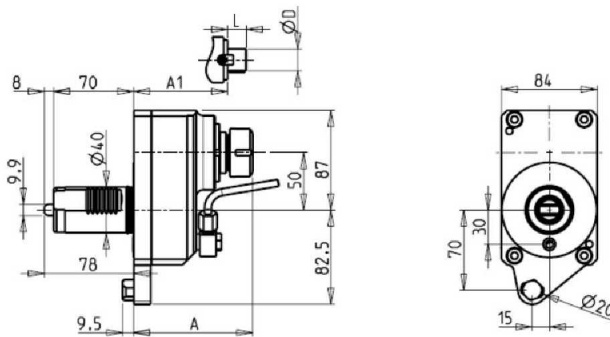
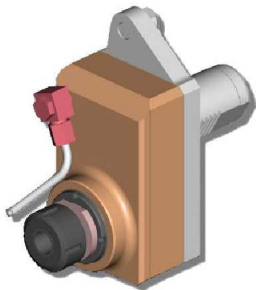

PartNumber	Description	Spindle	I	RPM	Ext Coolant	A	A1	D	L
MZK0011232	Geared Down 1:2 ER32 Redirected	ER32	2:1	2250	X	118.1			
MZK0011227	Geared Down 1:2 Mill Head D=27mm, L=21mm Redirected	27x21	2:1	2250	X		90	27	21

SQT 200-250 12 Station

DRIVEN

AXIAL DRIVEN TOOL

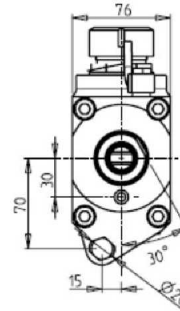
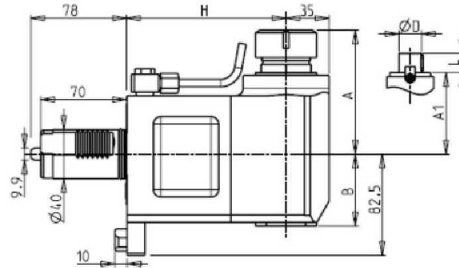
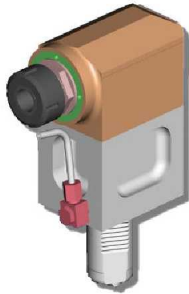

PartNumber	Description	Spindle	I	RPM	Coolant Thru	Ext Coolant	A	A1	B	D	H	L
MZK0020132	ER32 Standard	ER32	1:1	4500		X	101.1		58.5		130	
MZK0021032	ER32 Coolant Through *	ER32	1:1	4500	X	X	101.1		82		130	
MZK0021132	ER32 Standard H=80mm	ER32	1:1	4500		X	101.1		58.5		80	
MZK0020022	Milling Head D=22mm, L=19mm	22x19	1:1	4500		X		78.5	58.5	22	130	19
MZK0020027	Milling Head D=27mm, L=21mm	27x21	1:1	4500		X		78.5	58.5	27	130	21

* Coolant Through tools are designed for 1000 psi.
They require 5 Micron Filtration and **CANNOT** be run dry.

AXIAL DRIVEN OPPOSITE FACE TOOL

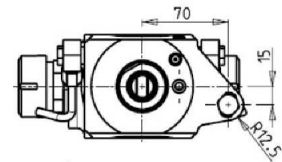
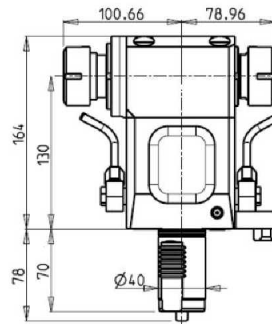
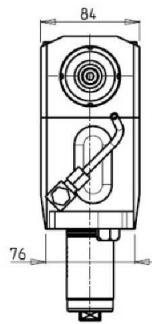
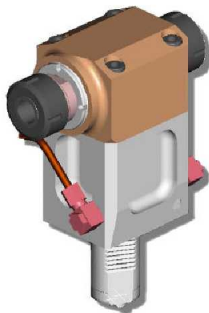

PartNumber	Description	Spindle	I	RPM	Ext Coolant
MZK0160232	Opposite Face Double Outer ER32/ER32	ER32 + ER32	1:1	4500	X

SQT 200-250 12 Station

DRIVEN

0-90 ADJUSTABLE ANGLE DRIVEN TOOL

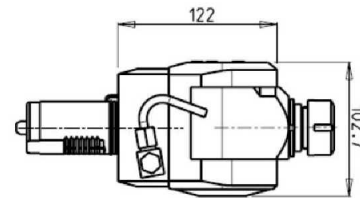
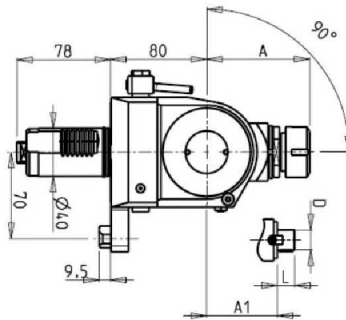
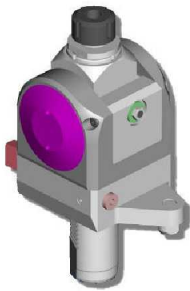

PartNumber	Description	Spindle	I	RPM	Ext Coolant	A	A1	D	L
MZK0100020	Adjustable Angle (0-90) ER20	ER20	1:1	4500	X	84.16			
MZK0100025	Adjustable Angle (0-90) ER25	ER25	1:1	4500	X	85.66			
MZK0101617	Adj. Angle (0-90) Milling Head D=16mm, L=17mm	16x17	1:1	4500	X		65	16	17
MZK0102219	Adj. Angle (0-90) Milling Head D=22mm, L=19mm	22x19	1:1	4500	X		66	22	19
MZK0101905	Adjustable Angle (0-90) Mill Head D=3/4, L=3/4	3/4x3/4	1:1	4500	X		65	3/4	3/4

Note : Wrenches are provided with the purchase of Specialty Toolholders

0-180 ADJUSTABLE ANGLE DRIVEN TOOL

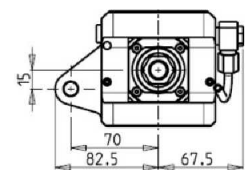
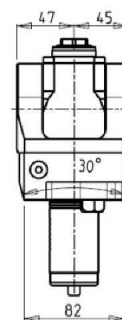
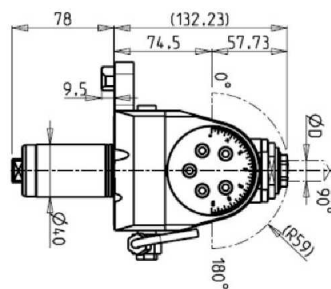
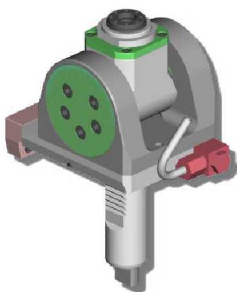

PartNumber	Description	Spindle	I	RPM	Ext Coolant	D MAX
MZK0110020	Adjustable Angle (0-180) ER20A	ER20A	1:1	4500	X	13

Note : Wrenches are provided with the purchase of Specialty Toolholders

SQT 200-250 12 Station

STATIC

RADIAL SINGLE TOOL STATIC HOLDER

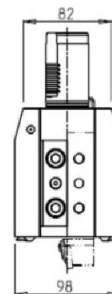
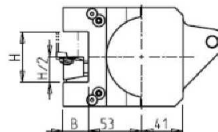
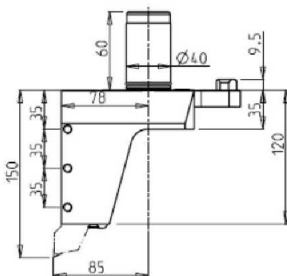
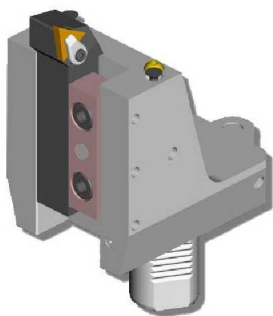

PartNumber	Description	Number of Tools	Dimensions	B	H
MZK0032540	Radial Single Tool : 1"	1/2	Inch	1"	2"
MZK0032500	Radial Single Tool : 25mm	1/2	mm	25	50

RADIAL SINGLE TOOL DOUBLE SIDED STATIC HOLDER

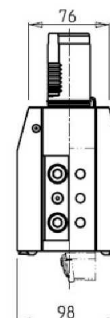
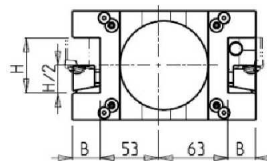
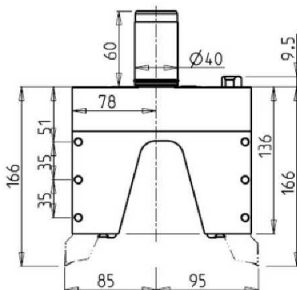
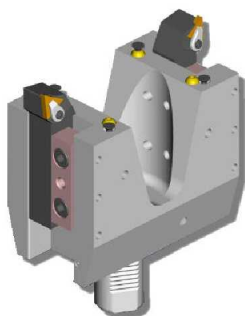

PartNumber	Description	Number of Tools	Dimensions	B	H
MZK0042540	Radial Double Tool : 1"	2/4	Inch	1"	2"
MZK0042500	Radial Double Tool : 25mm	2/4	mm	25	50

RADIAL DOUBLE BLADE HOLDER

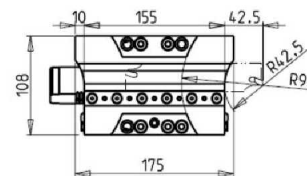
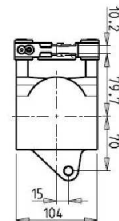
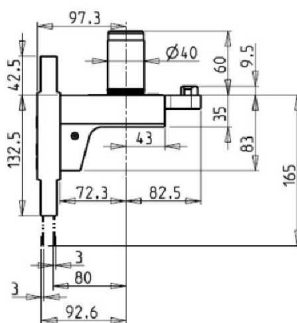
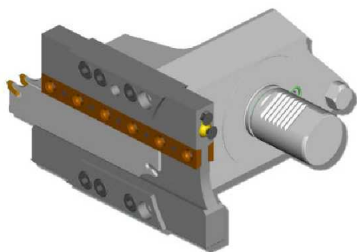

PartNumber	Description	Number of Tools
MZK0060132	Radial Double Blade Holder	1

SQT 200-250 12 Station

STATIC

AXIAL SINGLE TOOL STATIC HOLDER

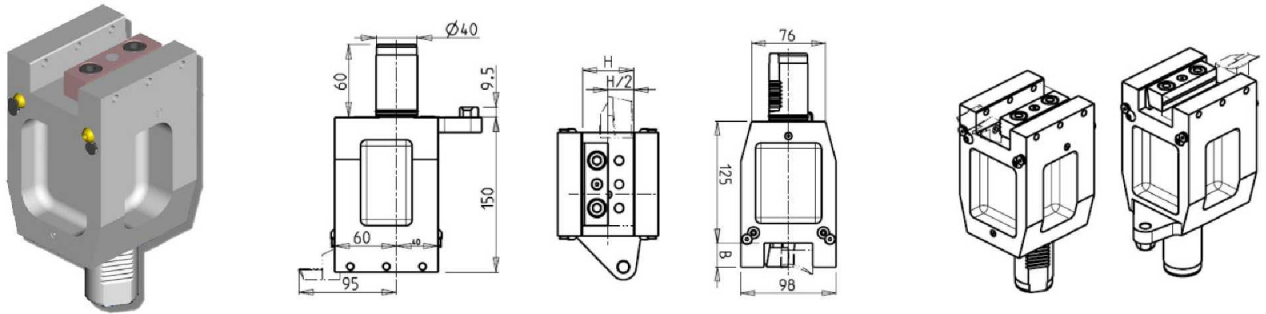

PartNumber	Description	Mazak Ref	Number of Tools	Dimensions	B	H
MZK0052540	Axial Single Tool: 1"		1/2	Inch	1"	2"
MZK0052500	Axial Single Tool: 25mm	T03005	1/2	mm	25	50

AXIAL SINGLE BORING BAR HOLDER 130mm INTERAXIS

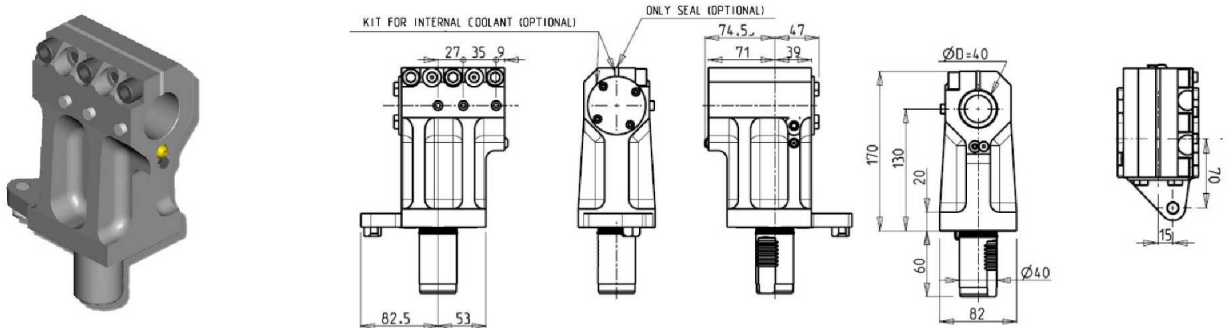

PartNumber	Description	Number of Tools	Coolant Thru	Ext Coolant	Dimensions	D	H
MZK0073810	Axial Boring Bar Holder: 1 1/2" Centerline 130mm	1	OPTION	X	Inch	1 1/2"	130
KIT1003004	1 1/2" Plug and Seal to Make BBH Coolant Through						
MZK0074000	Axial Boring Bar Holder: 40mm Centerline 130mm	1	OPTION	X	mm	40	130
KIT1003003	40mm Plug and Seal to Make BBH Coolant Through						

SQT 200-250 12 Station

STATIC

AXIAL SINGLE BORING BAR HOLDER 140mm INTERAXIS

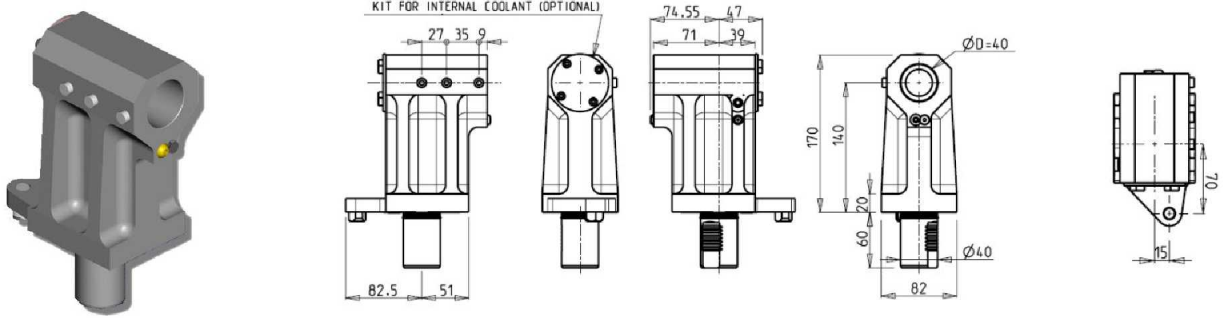

PartNumber	Description	Number of Tools	Coolant Thru	Ext Coolant	Dimensions	D	H
MZK0083810	Axial Boring Bar Holder: 1 1/2" Centerline 140mm	1	OPTION	X	Inch	1 1/2"	140
KIT1000004	1 1/2" Plug to Make BBH Coolant Through						
MZK0084000	Axial Boring Bar Holder: 40mm Centerline 140mm	1	OPTION	X	mm	40	140
KIT1000003	40mm Plug to Make BBH Coolant Through						

Table of Contents

Part Number Index

K

KIT1000003	40mm Plug to Make BBH Coolant Through	7
KIT1000004	1 1/2" Plug to Make BBH Coolant Through	7
KIT1003003	40mm Plug and Seal to Make BBH Coolant Through	6
KIT1003004	1 1/2" Plug and Seal to Make BBH Coolant Through	6

M

MZK0010017	Milling Head D=16mm, L=17mm Redirected	1
MZK0010019	Milling Head D=22mm, L=19mm Redirected	1
MZK0010025	ER25 Redirected	1
MZK0010027	Milling Head D=27mm, L=21mm Redirected	1
MZK0010032	ER32 Redirected	1
MZK0011227	Geared Down 1:2 Mill Head D=27mm, L=21mm Redirected	2
MZK0011232	Geared Down 1:2 ER32 Redirected	2
MZK0012125	Geared Up 2:1 ER25 Redirected	2
MZK0020022	Milling Head D=22mm, L=19mm	3
MZK0020027	Milling Head D=27mm, L=21mm	3
MZK0020132	ER32 Standard	3
MZK0021032	ER32 Coolant Through *	3
MZK0021132	ER32 Standard H=80mm	3
MZK0032500	Radial Single Tool : 25mm	5
MZK0032540	Radial Single Tool : 1"	5
MZK0042500	Radial Double Tool: 25mm	5
MZK0042540	Radial Double Tool: 1"	5
MZK0052500	Axial Single Tool: 25mm	6
MZK0052540	Axial Single Tool: 1"	6
MZK0060132	Radial Double Blade Holder	5
MZK0073810	Axial Boring Bar Holder: 1 1/2" Centerline 130mm	6
MZK0074000	Axial Boring Bar Holder: 40mm Centerline 130mm	6
MZK0083810	Axial Boring Bar Holder: 1 1/2" Centerline 140mm	7
MZK0084000	Axial Boring Bar Holder: 40mm Centerline 140mm	7
MZK0090225	ER25A Standard	1
MZK0090232	ER32 Standard	1
MZK0091232	ER32 Coolant Through *	1
MZK0092219	Milling Head D=22mm, L=19mm	1
MZK0100020	Adjustable Angle (0-90) ER20	4
MZK0100025	Adjustable Angle (0-90) ER25	4
MZK0101617	Adj. Angle (0-90) Milling Head D=16mm, L=17mm	4
MZK0101905	Adjustable Angle (0-90) Mill Head D=3/4, L=3/4	4
MZK0102219	Adj. Angle (0-90) Milling Head D=22mm, L=19mm	4
MZK0110020	Adjustable Angle (0-180) ER20A	4
MZK0160232	Opposite Face Double Outler ER32/ER32	3