



Doosan Infracore
Machine Tools

BMT85

DRIVEN AND STATIC TOOLING CATALOG



10139 BERGIN RD.
HOWELL, MI 48843
PHONE : 877-91-TOOLS (810-632-4446)
FAX: 877-92-TOOLS (810-632-4467)
EMAIL: info@mdtooling.com
WEBSITE: www.mdtooling.com

March 2009

Live Tooling



Live Tool Technology

M. T. Marchetti, a major live tool manufacture in northern Italy, is a leader in live tool technology. The formula is simple. Use only the best angular contact high-speed bearings available. Add to this exacting tolerances for all ground shafts, gears and bearing pocket features. Next, develop a sealed system that **will not** allow any contamination from chips or coolant.

Top this all off with a superior design and you end up with a live tool that is more rigid, faster and will last longer. **We back this up with a 2-Year factory warranty.**

Our Live Tool Warranty

Our tooling will give years of service in the most demanding applications. The superior design and rugged construction has proven this over the last 12 years. The reliability of our tools allows us to provide a 2-year factory warranty.

MD TOOLING will repair any defective tool holders for a period of 2 years from the date of purchase.

Product Range

We have the largest range of live tooling available for most major machine tool manufactures.

Our available products include an extensive line of standard live tooling as well as specialty toolholders such as 0-90 and 0-180 adjustable angle tool holders, gear hobbers, and even worm gear generators. Our product range includes geared up holders to 60,000 RPM and are engineered for 1,000 PSI coolant through.

We are an industry leader in providing complete tooling solutions with hundreds of static tool options as well.

Technical Support

Here at MD Tooling we have a full technical support department with over 25 years of CNC experience.

Our highly qualified staff can help with part processing, tooling up a job from a blue print and even assist with part programming. Applications Engineers are always available by phone to answer any questions you may have about our tooling or any other CNC related issue.

Stock and Replenishment

MD Tooling maintains an extensive inventory of tooling in our warehouse in Michigan. Our current "fill" rate on orders is 93% from our stock in Michigan for same day shipping.

Should you require a non-stock item, our manufacturer, M.T. Marchetti also maintains a large inventory in Italy. Tooling can be obtained in as little as 3-5 business days.

Shipping

MD Tooling realizes that when you need tooling, often you can't wait until the next day. We process orders and ship from available stock right up until 5PM EST to make certain we get your tooling solutions to you as quickly as possible.

We regularly ship throughout the day via DHL, UPS, FedEx or any other carrier that a customer requests.



10139 Bergin Road

Howell, MI 48843

Phone: 810 632-4446

Fax: 810 632-4467

Email: info@mdtooling.com

Web: www.mdtooling.com

- 2-Year Warranty on all live tools.
- Quality tooling at highly competitive pricing.
- Extensive inventory. We currently ship over 93% of all orders same day.
- Fast, Friendly, Reliable Service!
- More specialty tool holders than any other manufacturer.
- Custom tool holders available.
- All available tooling may not be shown in this catalog. If you can't find the holder you're looking for, please contact this office for assistance.



Table of Contents

Categorized Listing

BMT85	1
DRIVEN	1
RADIAL DRIVEN TOOL	1
AXIAL DRIVEN TOOL	1
GEAR HOBBER	2
STATIC	3
RADIAL STATIC TOOL	3
AXIAL STATIC TOOL	3
AXIAL SINGLE BORING BAR HOLDER	4

BMT85

DRIVEN

RADIAL DRIVEN TOOL

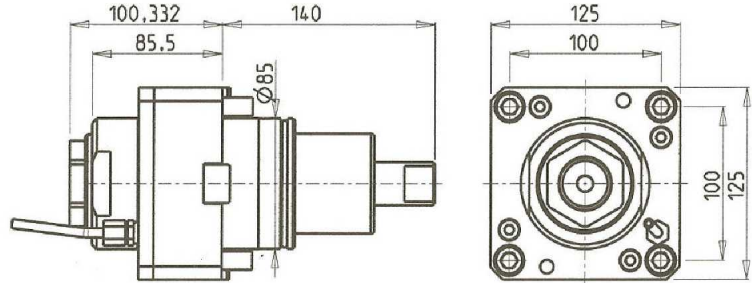
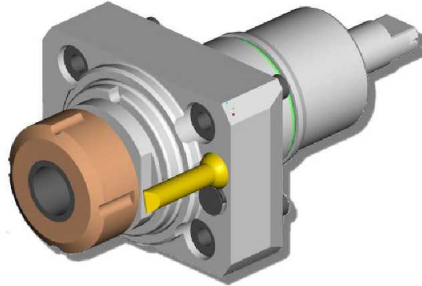

Part Number	Description	Doosan Reference	Spindle	I	RPM	Coolant Thru	Ext Coolant
DWO 0160150	ER50A Standard	R78756	ER50A	1:1	3000		X
DWO 0160250	ER50A Coolant Through *	R78770	ER50A	1:1	3000	X	X

* Coolant Through tools are designed for 1000 psi.
They require 5 Micron Filtration and **CANNOT** be run dry.

AXIAL DRIVEN TOOL

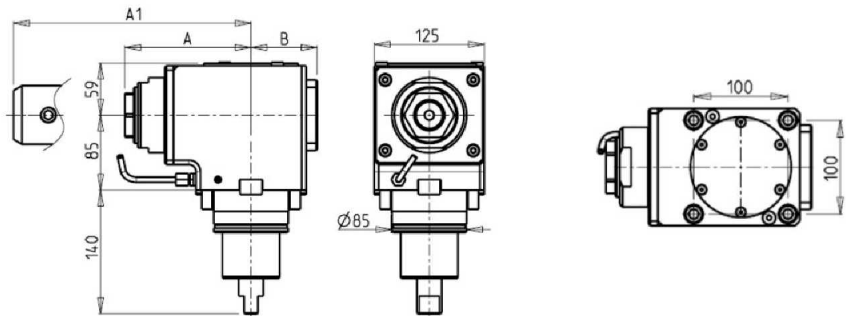
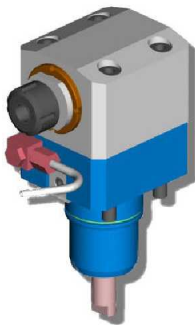

Part Number	Description	Doosan Reference	Spindle	I	RPM	Coolant Thru	Ext Coolant	A	A1	B
DWO 0150150	ER50A Standard	R78757	ER50A	1:1	3000		X	143.33	75	
DWO 0150250	ER50A Coolant Through *	R78771	ER50A	1:1	3000	X	X	143.33	91	
DWO 0151250	ER50A Coolant Through *		ER50A	1:1	3000	X	X	143.33		86
DWO 0150140	Weldon 40 Coolant Through *		Weldon 40	1:1	3000	X	X		175.5	91

* Coolant Through tools are designed for 1000 psi.
They require 5 Micron Filtration and **CANNOT** be run dry.

BMT85

DRIVEN

GEAR HOBBER

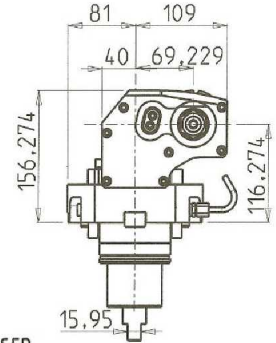
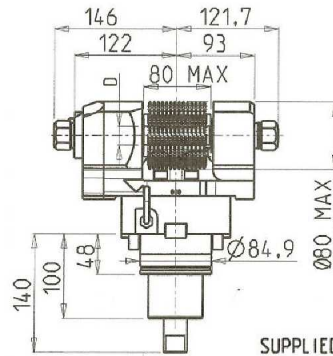
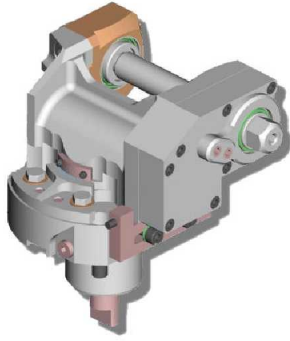

SUPPLIED WITH: N°1 SHAFT+SPACER

Part Number	Description	I	RPM	Ext Coolant	D mm	D Inch
DWO 0181100	Driven Gear Hobber 1:1	1:1	3000	X	16-22-27-32	3/4"-1"-1 1/4"
DWO 0182100	Driven Gear Hobber 2:1	2:1	1500	X	16-22-27-32	3/4"-1"-1 1/4"

Note : Wrenches are provided with the purchase of Specialty Toolholders

BMT85

STATIC

RADIAL STATIC TOOL

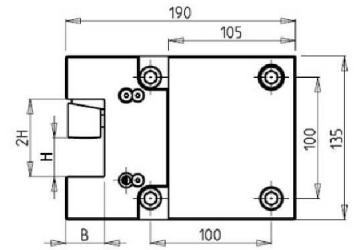
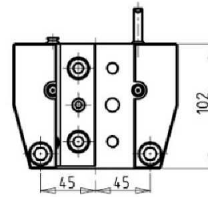
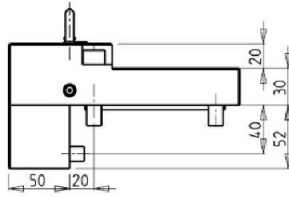
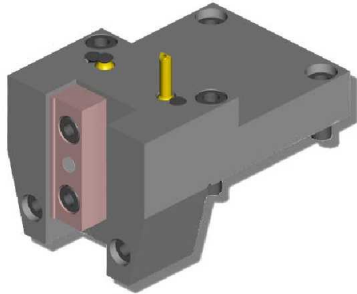

Part Number	Description	Number of Tools	Dimensions	B	H
DWO 0323175	Radial Static Tool 1 1/4" x 1 1/4"	1	Inch	1 1/4"	1 1/4"
DWO 0323200	Radial Static Tool 32mm x 32mm	1	mm	32	32

AXIAL STATIC TOOL

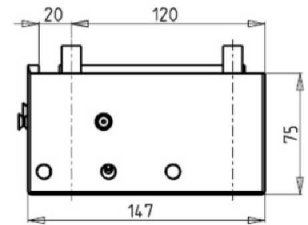
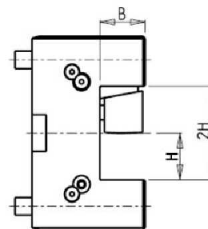
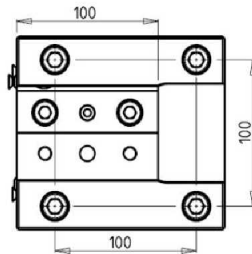
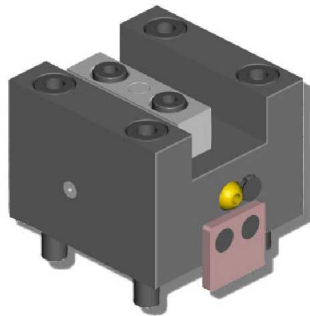

Part Number	Description	Number of Tools	Reversible Main / Sub Spindle	Dimensions	B	H
DWO 0333175	Axial Static Tool 1 1/4" x 1 1/4"	1	X	Inch	1 1/4"	1 1/4"
DWO 0333200	Axial Static Tool 32mm x 32mm	1	X	mm	32	32

BMT85

STATIC

AXIAL SINGLE BORING BAR HOLDER

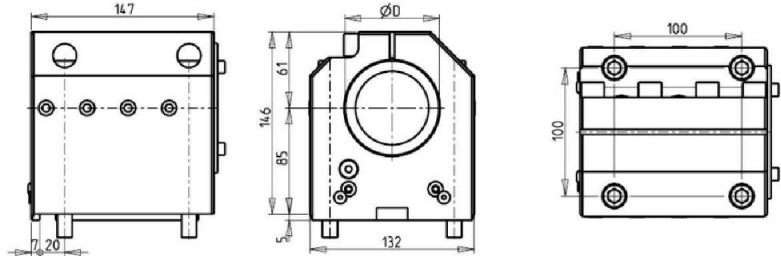
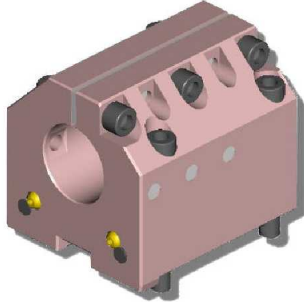

Part Number	Description	Number of Tools	Coolant Thru	Ext Coolant	Dimensions	D
DWO 0347620	Axial Single Boring Bar Holder : 3"	1	OPTION	X	inch	3"
DWO 0348000	Axial Single Boring Bar Holder : 80mm	1	OPTION	X	mm	80
KIT 1002014	Plug & Seal Kit to make 3" BBH Coolant Through					
KIT 1002013	Plug & Seal Kit to make 80mm BBH Coolant Through					

Table of Contents

Part Number Index

D

DWO 0150140	Weldon 40 Coolant Through *	1
DWO 0150150	ER50A Standard	1
DWO 0150250	ER50A Coolant Through *	1
DWO 0151250	ER50A Coolant Through *	1
DWO 0160150	ER50A Standard	1
DWO 0160250	ER50A Coolant Through *	1
DWO 0181100	Driven Gear Hobber 1:1	2
DWO 0182100	Driven Gear Hobber 2:1	2
DWO 0323175	Radial Static Tool 1 1/4" x 1 1/4"	3
DWO 0323200	Radial Static Tool 32mm x 32mm	3
DWO 0333175	Axial Static Tool 1 1/4" x 1 1/4"	3
DWO 0333200	Axial Static Tool 32mm x 32mm	3
DWO 0347620	Axial Single Boring Bar Holder : 3"	4
DWO 0348000	Axial Single Boring Bar Holder : 80mm	4

K

KIT 1002013	Plug & Seal Kit to make 80mm BBH Coolant Through	4
KIT 1002014	Plug & Seal Kit to make 3" BBH Coolant Through	4